

Cruise Control

Main Switch Replacement

CAUTION:

- All SRS electrical wiring harnesses are covered with yellow outer insulation.
- Before disconnecting the SRS wire harness, install the short connector on the airbag (see page 23-323).
- Replace the entire affected SRS harness assembly if it has an open circuit or damaged wiring.

1. Remove the dashboard lower cover and disconnect the 2-P connectors from the floor wire harness.

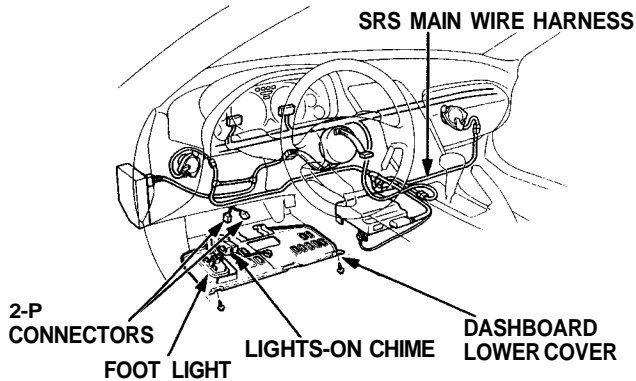

2. Remove the dashboard center panel.

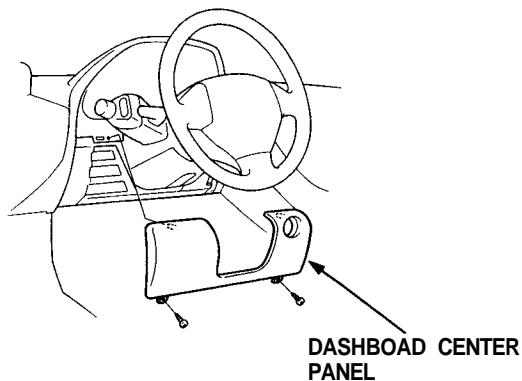

3. Remove the tilt cover.

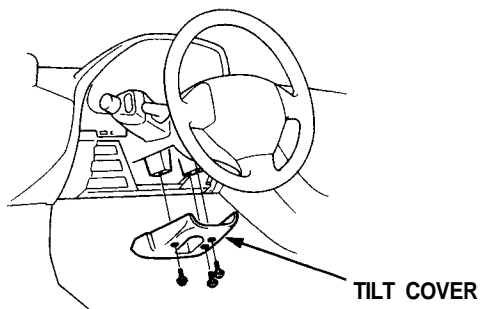

4. Remove the steering column lower cover and upper cover.

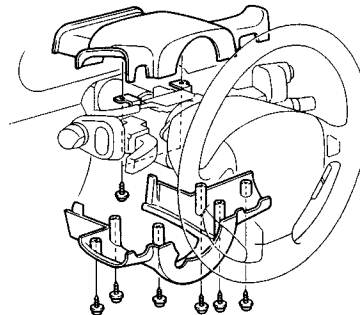

5. Disconnect the 16-P connector and the 10-P connector.

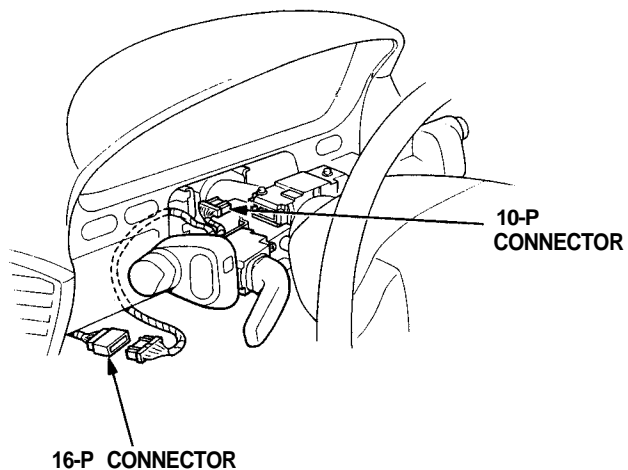

CAUTION: Be careful not to damage the SRS wires.



6. Remove the 4 screws from the lighting switch.
7. Remove the lighting switch (main switch).

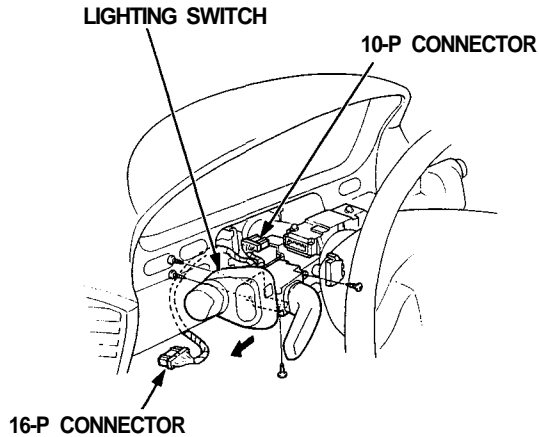

Main Switch Test

1. Remove the dashboard lower panel and dashboard center cover.
2. If necessary, remove the knee bolster.
3. Check for continuity between the terminals in each switch position according to the table.

Terminal Position	5	15		1	7		16
OFF		○—○			○—○		
ON	○—○		○—○			○—○	

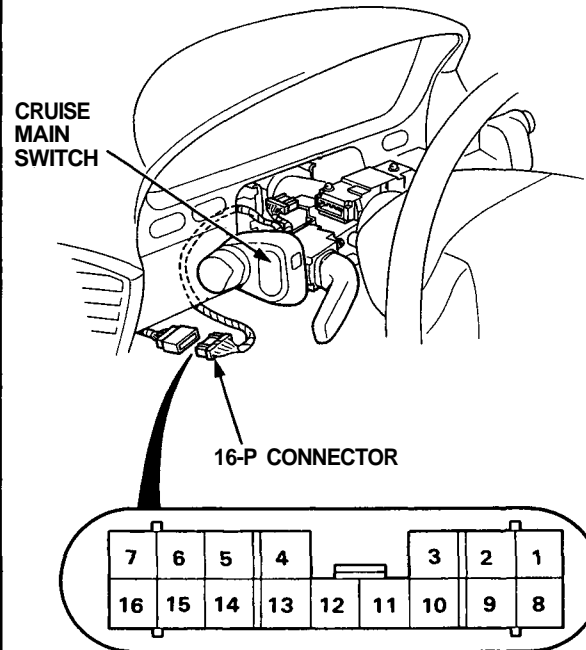

View from terminal side

