

Seat Belts

Inspection

Retractor Inspection

1. With the retractor installed, check that the belt can be pulled out freely.
2. Make sure that the belt does not lock when the retractor is tilted over slowly to 15° from the mounted position. The belt should lock when the retractor is tilted over 40°

CAUTION: Do not attempt to disassemble the retractor.

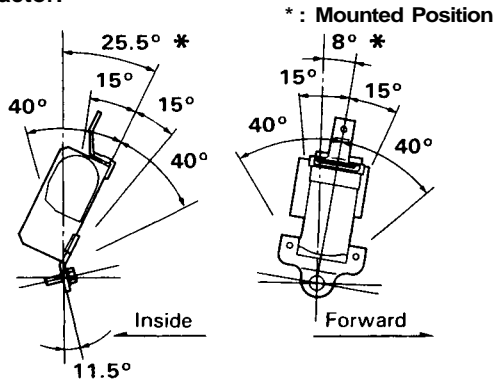

3. Replace the belt with a new one if there is any abnormality.

On the Car Belt Inspection

1. Check that the belt is not twisted or caught on anything.
2. After installing an anchor, check for free movement on its retaining bolt. If necessary, remove the bolt and check that the washers and other parts are not damaged or installed improperly.
3. Check the belts for fouling, damage or discoloration. Clean with a shop towel if fouled.

CAUTION: Use only soap and water to clean.

Dirt build-up in the metal loops of the seat belt anchors can cause the belts to retract slowly. Wipe the inside of the loops with a clean cloth dampened in isopropyl alcohol.

4. Check that the belt does not lock when pulled out slowly. The belt is designed to lock only during a sudden stop or impact.
5. Make sure that the belt will retract automatically when released.
6. Replace the belt with a new one if there is any abnormality.

Child Seat Anchor Plate

An attachment point is provided for a child restraint system which uses a top tether. The tether bracket and bolt are available at your Acura dealer. The tether attachment point is located on the panel behind the passenger's seat-back.

1. Adjust the passenger seat fully forward to make room behind the seat back.
2. Using the dimensions shown, measure and mark the location of the attachment point on the interior panel.
3. Use a razor blade or sharp knife to carefully cut a 1 inch diameter circle at the point you marked. Cut through one layer at a time. You will need to remove two layers to reach the tether attachment.
4. Install the tether bracket and bolt and tighten to: 16 lb-ft (22 N·m)

Make sure to route the tether through the space between the headrest and seat.

8 x 1.25 mm
22 N·m (2.2 kg·m, 16 lb-ft)

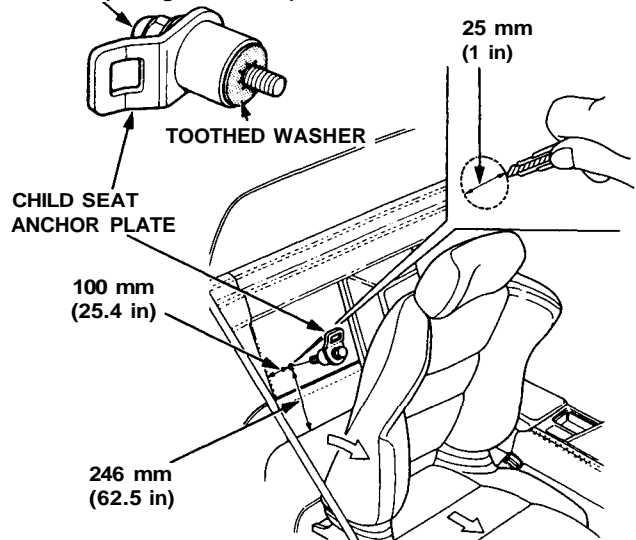

NOTE:

- Do not remove the toothed washer from the child seat anchor plate. Use the child seat anchor plate with the toothed washer attached to it.
- When installing a child seat, follow the instructions of the manufacturer of the child seat.
- Additional anchor plates are available.

▲ WARNING Do not use the anchor plate for any other purpose; it is designed exclusively for installation of a child seat.