

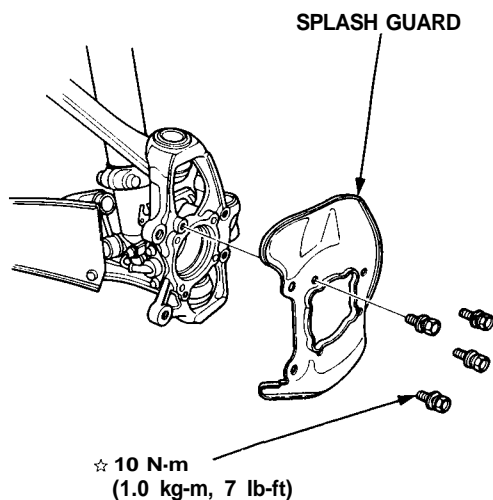

Removal

1. Remove the front wheel and bearing unit assembly (page 18-15).
2. Remove the splash guard from the knuckle.



3. Remove the lower control arm guard.

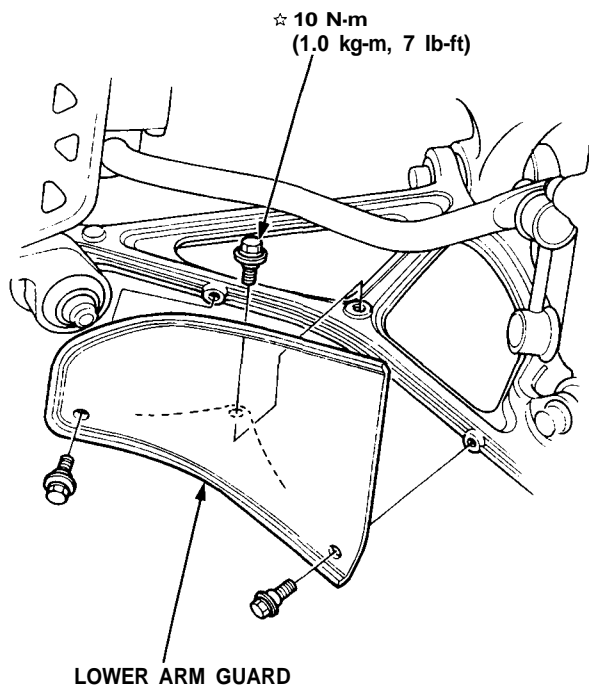

NOTE: Use the ball joint removers, **07MAC-SL00100** (32 mm) and **07MAC—SL00200** (28 mm), to separate the ball joints from the suspension or steering arm.

CAUTION:

- Be careful not to damage the ball joint boot.
- Torque the castle nut to the lower torque specification, then tighten it only far enough to align the slot with the pin hole. Do not align the nut by loosening.

4. Clean any dirt or grease off the ball joint.
5. Remove the cotter pin from the steering arm and remove the nut.
6. Apply grease to the special tool on the areas shown. This will ease installation of the tool and prevent damage to the pressure bolt threads.

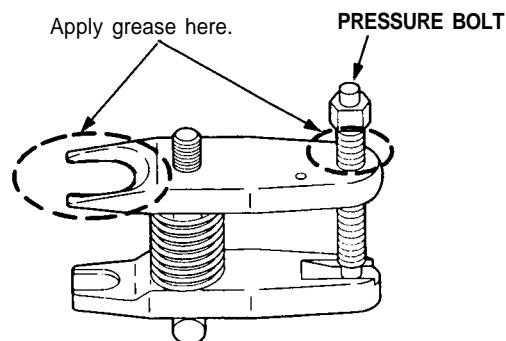

7. Install a 12 mm hex nut on the ball joint. Be sure that the hex nut is flush with the ball joint pin end to prevent damage to the threaded end of the ball joint.
8. Use the ball joint remover, **07MAC—SL00200** (28 mm), as shown. Insert the jaws carefully, making sure you do not damage the ball joint boot. Adjust the jaw spacing by turning the pressure bolt.

NOTE: If necessary, apply penetrating type lubricant to loosen the ball joint.

☆ CASTLE NUT
44 N-m
(4.4 kg-m, 32 lb-ft)

BALL JOINT REMOVER, 28 mm
07MAC-SL00200

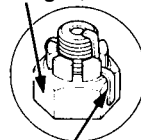

COTTER PIN

Replace.
On reassembly, bend the pin as shown.

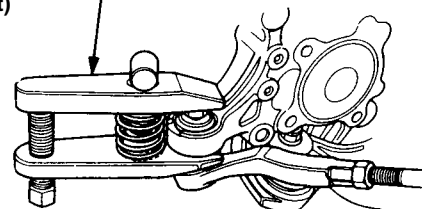

☆ Corrosion resistant bolt/nut

(cont'd)

Knuckle/Control Arms/Compliance Pivot

Removal (cont'd)

9. Once the tool is in place, turn the adjusting bolt as necessary to make the jaws parallel. Then hand-tighten the pressure bolt, and recheck the jaws to make sure they are still parallel.

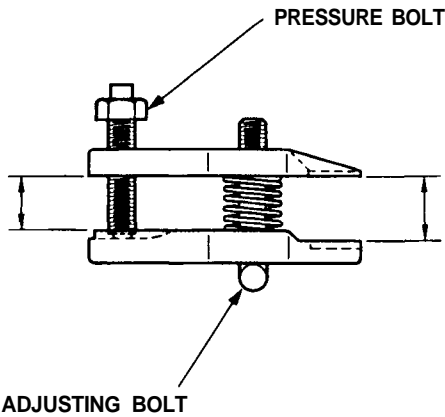

10. With a wrench, tighten the pressure bolt until the ball joint shaft pops loose from the steering arm.

⚠ WARNING Wear eye protection. The ball joint can break loose suddenly and scatter dirt or other debris in your eyes.

11. Remove the tool, then remove the nut from the end of the ball joint and pull the ball joint out of the steering/suspension arm. Inspect the ball joint boot and replace it if damaged.

12. Remove the cotter pin and lower control arm ball joint nut.
13. Install the 12 mm hex nut on the ball joint. Be sure that the 12 mm hex nut is flush with the ball joint pin end, or the threaded section of the ball joint pin might be damaged by the ball joint remover.
14. Use the ball joint remover, 07MAC-SL00100 (32 mm), as shown on page 18-21 to separate the ball joint and lower control arm.

NOTE: If necessary, apply penetrating type lubricant to loosen the ball joint.

☆ 12 x 1.25 mm
CASTLE NUT
60 N-m
(6.0 kg-m, 43 lb-ft)

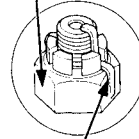

COTTER PIN

Replace.

On reassembly, bend the cotter pin as shown.

BALL JOINT REMOVER, 32 mm
07MAC - SL00100

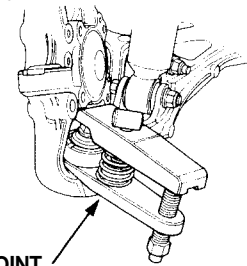

☆ Corrosion resistant bolt/nut

15. Remove the cotter pin and the upper ball joint nut.
16. Install the 12 mm hex nut on the ball joint. Be sure that the 12 mm hex nut is flush with the ball joint pin end, or the threaded section of the ball joint pin might be damaged by the ball joint remover.
17. Use the ball joint remover, 07MAC-SL00100 (32 mm), as shown on page 18-21 to separate the ball joint and upper arm.

NOTE: If necessary, apply penetrating type lubricant to loosen the ball joint.

COTTER PIN

Replace.

On reassembly,

bend the cotter pin as shown.

BALL JOINT REMOVER, 32 mm
07MAC - SL00100

☆ CASTLE NUT
12 x 1.25 mm
60 N-m
(6.0 kg-m, 43 lb-ft)

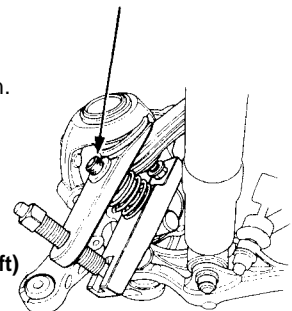
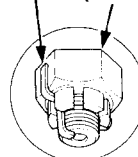

☆ Corrosion resistant bolt/nut



18. Remove the knuckle assembly.

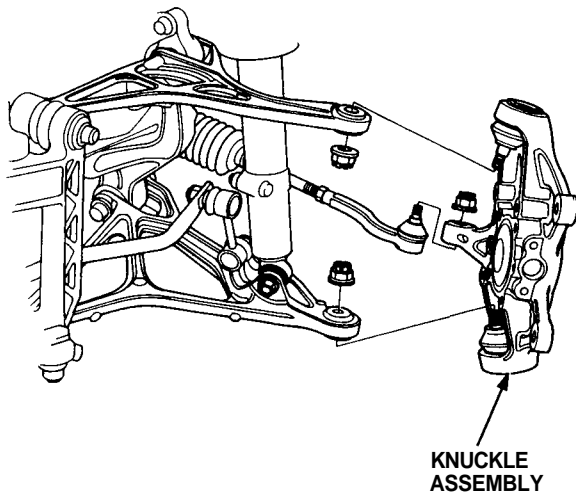

19. Separate the lower control arm and damper by removing the damper mounting bolt.

☆ DAMPER MOUNTING BOLT

☆ Corrosion resistant bolt/nut

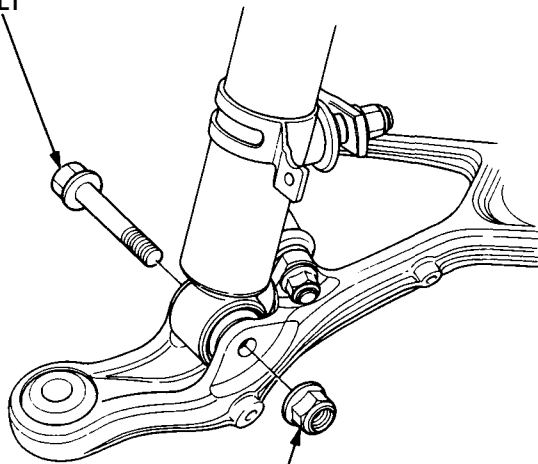

☆ SELF-LOCKING NUT
12 x 1.25 mm
Replace.
95 N-m (9.5 kg-m, 69 lb-ft)

20. Separate the lower control arm from the stabilizer link by removing the link connecting nut.

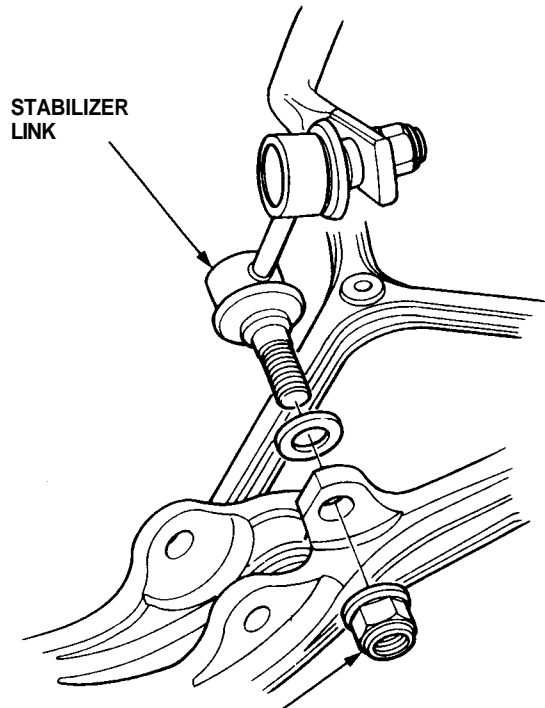

☆ SELF-LOCKING NUT
12 x 1.25 mm
85 N-m (8.5 kg-m, 62 lb-ft)

☆ Corrosion resistant bolt/nut

(cont'd)

Knuckle/Control Arms/Compliance Pivot

Removal (cont'd)

21. Remove the cotter pin and lower arm ball joint nut.
22. Install the 12 mm hex nut on the ball joint. Be sure that the 12 mm hex nut is flush with the ball joint pin end, or the threaded section of the ball joint pin might be damaged by the ball joint remover.
23. Use the ball joint remover, **07MAC-SL00100** (32 mm), as shown on page 18-21 to separate the ball joint and compliance pivot.

NOTE: If necessary, apply penetrating type lubricant to loosen the ball joint.

CAUTION: Avoid damaging the ball joint boot.

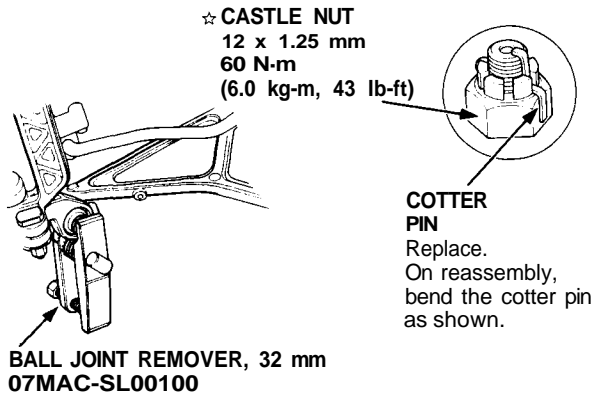

24. Remove the lower control arm by removing the adjusting bolt.

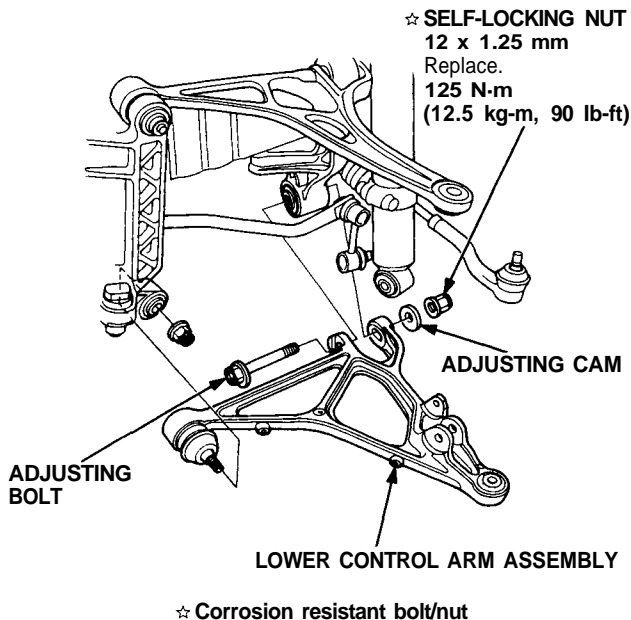

25. Remove the cotter pin and upper arm ball joint nut.
26. Install the 12 mm hex nut on the ball joint. Be sure that the 12 mm hex nut is flush with the ball joint pin end, or the threaded section of the ball joint pin might be damaged by the ball joint remover.
27. Use the ball joint remover, **07MAC-SL00100** (32 mm), as shown on page 18-21 to separate the ball joint and compliance pivot.

NOTE: If necessary, apply penetrating type lubricant to loosen the ball joint.

CAUTION: Avoid damaging the ball joint boot.

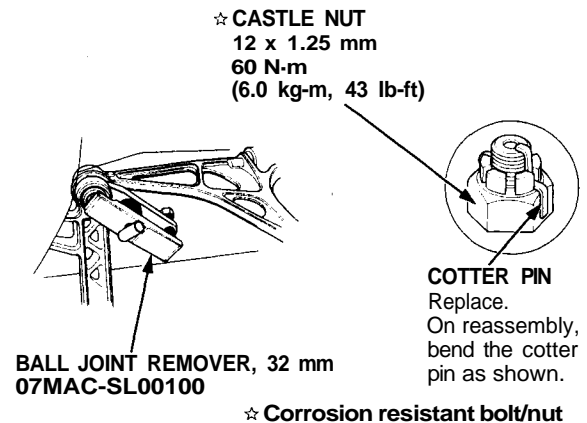

28. Remove the stabilizer bar bracket from the compliance pivot.
29. Remove the three lower compliance pivot bolts.

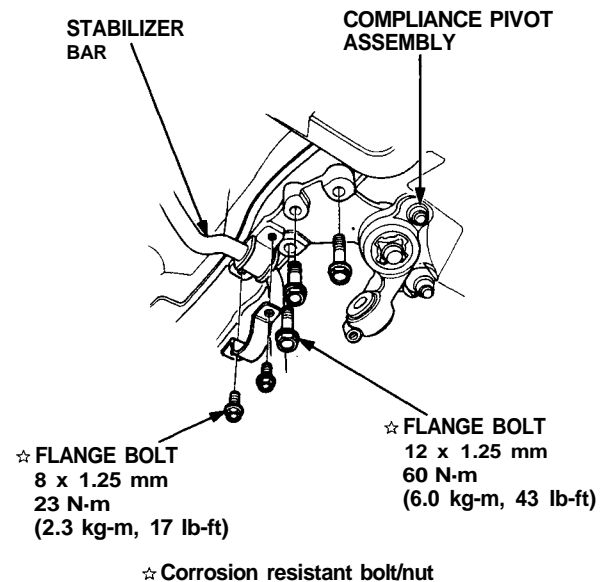



30. Remove the compliance pivot assembly by removing the bolts and nuts shown.

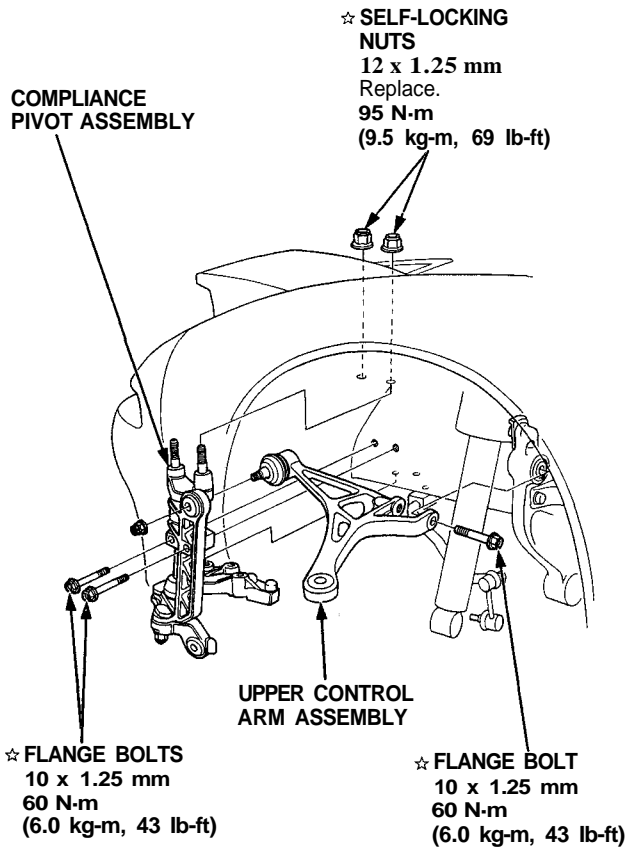

☆ Corrosion resistant bolt/nut

31. Remove the upper control arm assembly by removing the upper arm bolt.

NOTE:

- Install the compliance pivot bolts and nuts. Torque them to the specified torque in the order.
- Install the upper control arm on the frame before installing the compliance pivot assembly.

1. Loosly tighten the flange bolt (①).
2. Insert the stud bolts (②) into the frame.
3. Install the three flange bolts (③) and tighten to the specified torque.
4. Install the two flange bolts (④) and tighten to the specified torque.
5. Tighten the flange bolt (①).
6. Install the 12 mm self-locking nuts (⑤) and tighten to the specified torque.

