

# Transmission Assembly

## Installation

NOTE: Check that the two dowel pins are installed in the clutch housing.

1. Place the transmission on the transmission jack, and raise it to the engine level.
2. Set the release fork to the clutch housing, (see page, 13-9)
3. Install the 2 transmission housing mounting bolts and engine stiffener.
4. Install the 3 rear transmission mounting bolts.
5. Loosen the front engine mounting bolt, then install the 2 front engine mounting bolts to the transmission side.
6. Remove the transmission jack.
7. Install the clutch housing cover.

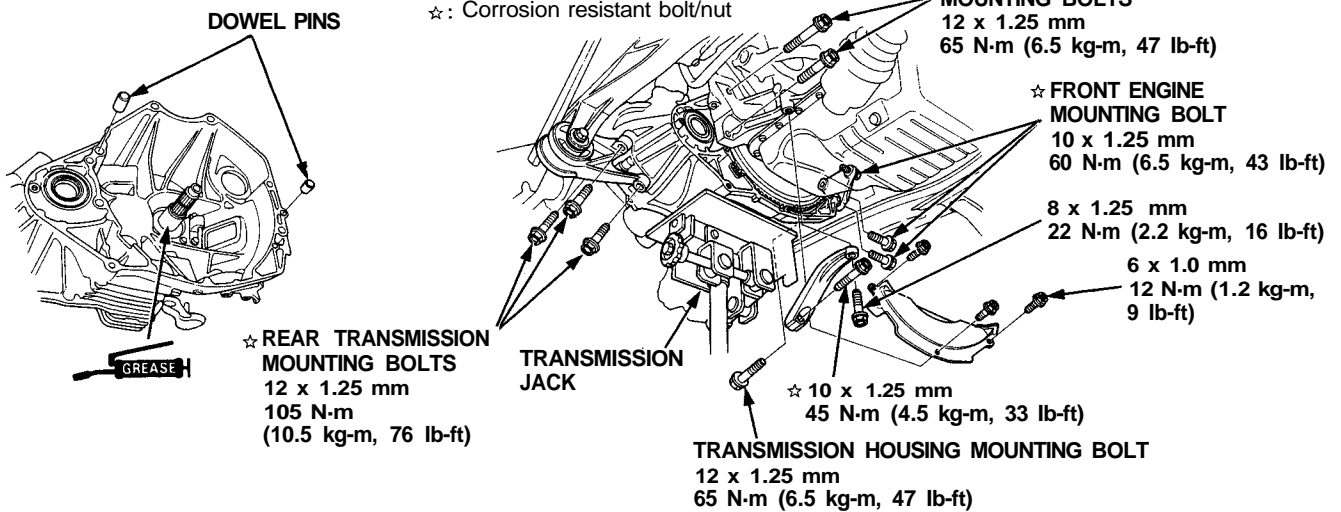
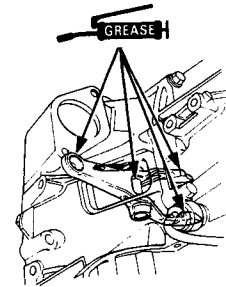

8. Install the release fork in the release hanger, then install the slave cylinder.
9. Install the shift cable and select cable.
- CAUTION: Take care not to bend the cables.**
10. Install the upper cover, change wire bracket and lower cover.
11. Install the upper control arm mounting bolt.

\* : Corrosion resistant bolt/nut

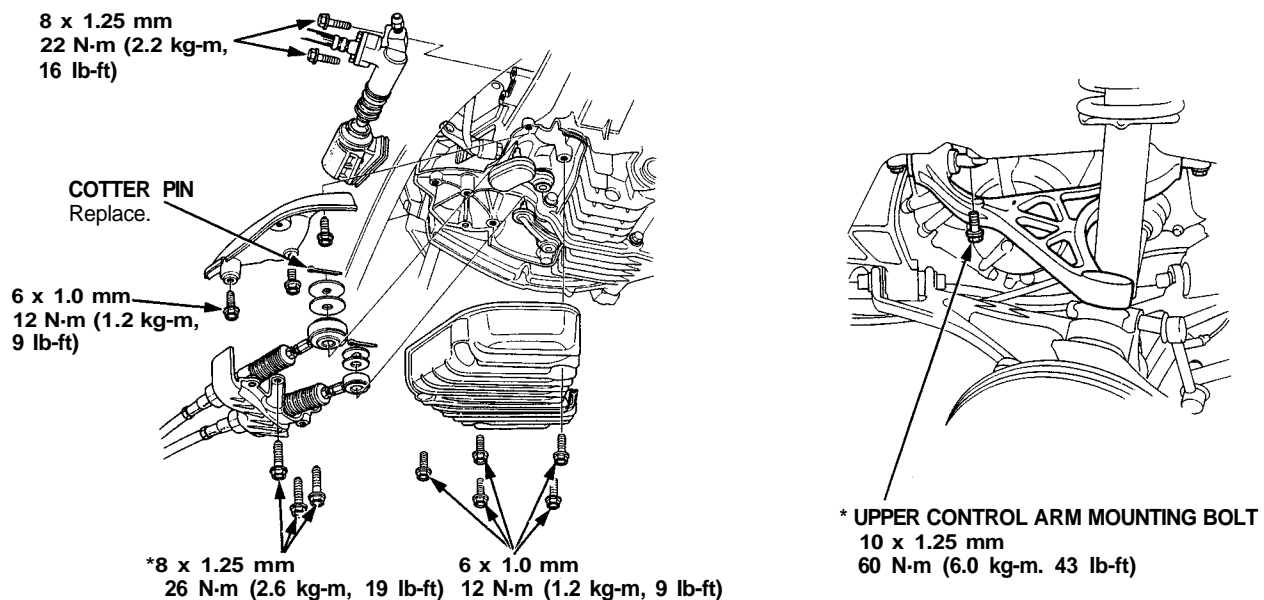



12. Install a new set ring on the end of the left driveshaft and intermediate shaft.
13. Install the left driveshaft.
14. Install the lower arm to the side beam.

**CAUTION:** Align the reference marks on the adjusting bolt, adjusting cam and lower control arm.

15. Install the damper fork bolt.
16. Install the ball joint nut to the toe control arm at the knuckle.

**CAUTION:** Make sure that the arrow marks on the toe control arm are aligned.

17. Install the ALB sensor wire clamp and parking brake cable holder.

☆: Corrosion resistant bolt/nut

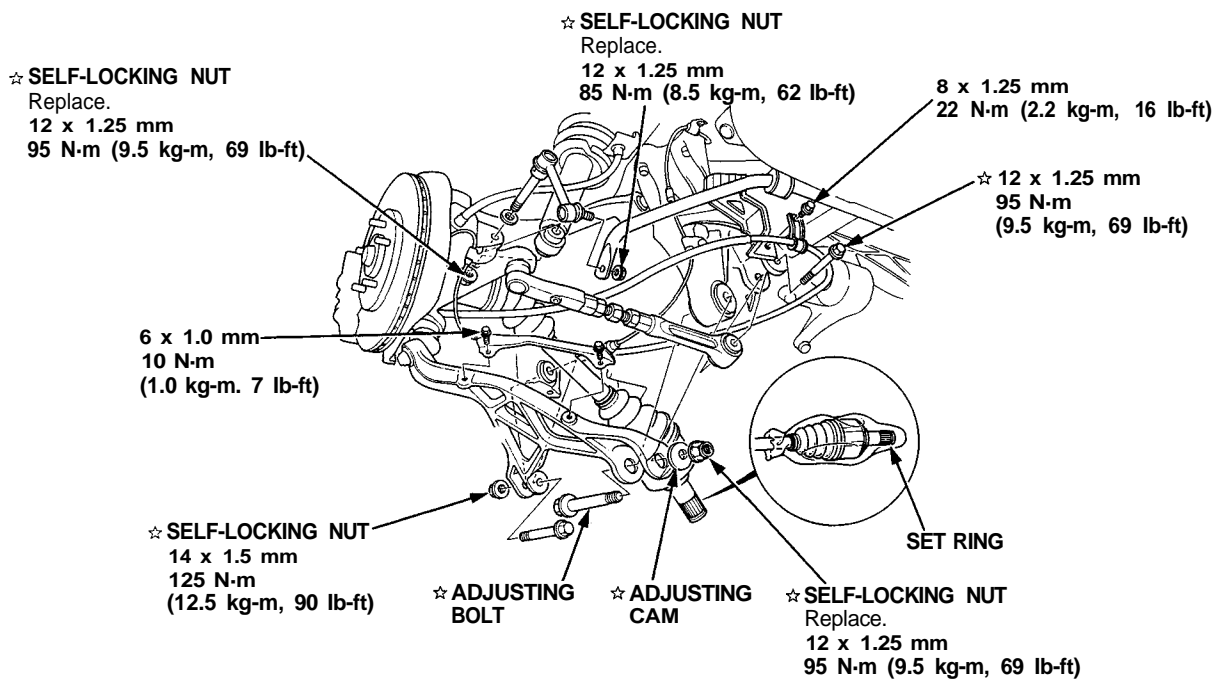

18. Install the intermediate shaft and tighten the intermediate shaft mounting bolts to the intermediate shaft support base.
19. Install the intermediate shaft heat cover.

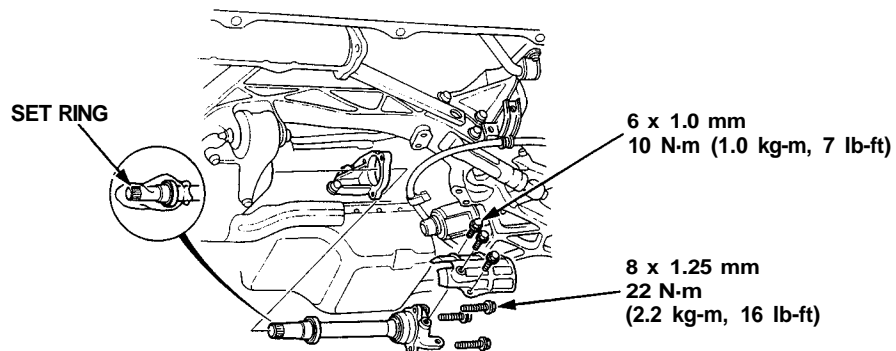

(cont'd)

# Transmission Assembly

## Installation (cont'd)

20. Install the right driveshaft onto the intermediate shaft.
21. Install the castle nut on the lower control arm at the knuckle.
22. Install the damper fork bolt.
23. Install the castle nut on the toe control arm at the knuckle.

**CAUTION: Make sure that the arrow marks on the toe control arm are aligned.**

24. Install the Anti-lock brake sensor wire clamp and parking brake cable holder.

☆: Corrosion resistant bolt/nut

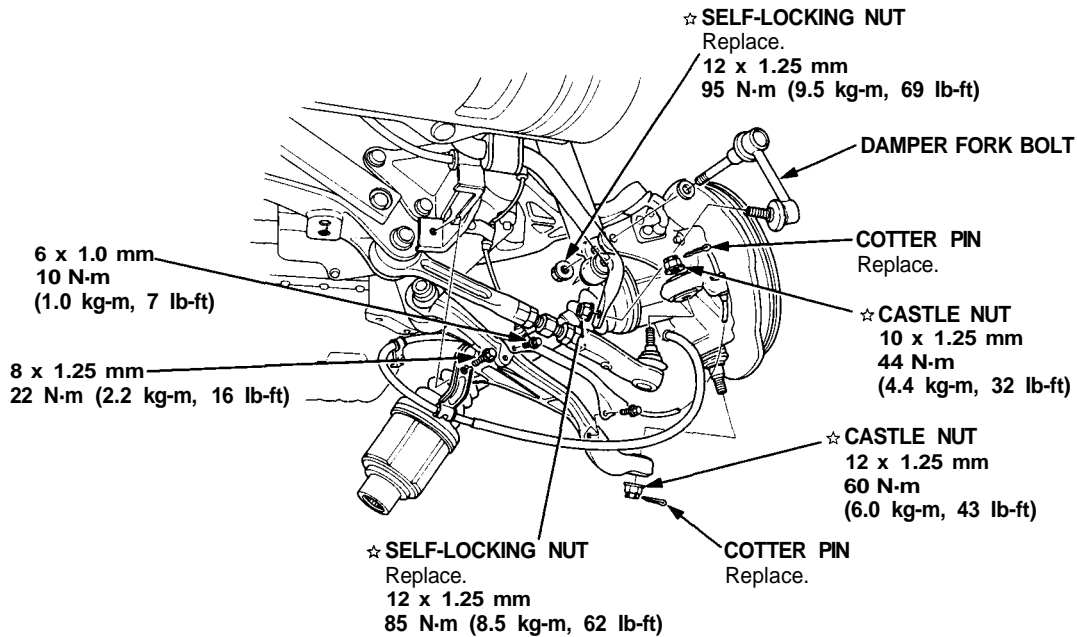

25. Install the front exhaust pipe A.
26. Install the rear beam rod.
27. Install the parking brake cable.

SELF-LOCKING NUT  
Replace.  
10 x 1.25 mm  
34 N-m (3.4 kg-m, 25 lb-ft)

☆: Corrosion resistant bolt/nut

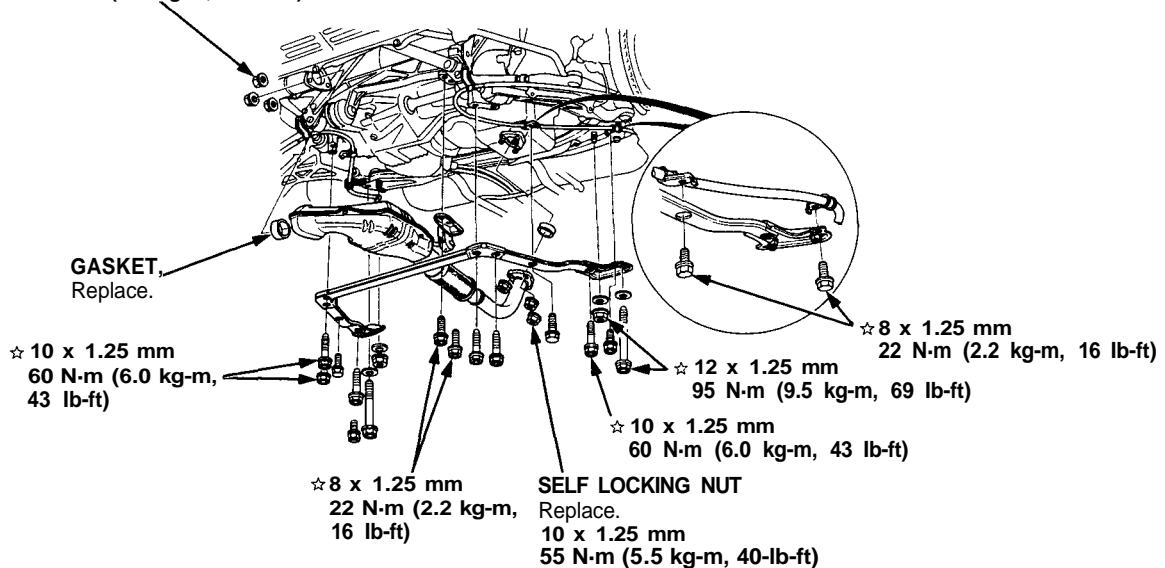

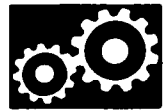

28. Install the transmission mount and 2 transmission housing mounting bolts.
29. Install the starter motor and connect the starter motor cables.
30. Install the transmission ground cable and jumper connector, and connect the back-up light switch, neutral switch and speed sensor connectors.
31. Install the control box and connect the control box connectors.

32. Install the air cleaner case.
33. Install the strut bar.
34. Refill the transmission with oil.
35. Connect the battery positive (+) and negative (-) cables to the battery.
36. Inspect the rear camber (see [section 18](#)).
37. Check the clutch operation.
38. Shift the transmission and check for smooth operation.

☆: Corrosion resistant bolt/nut

