

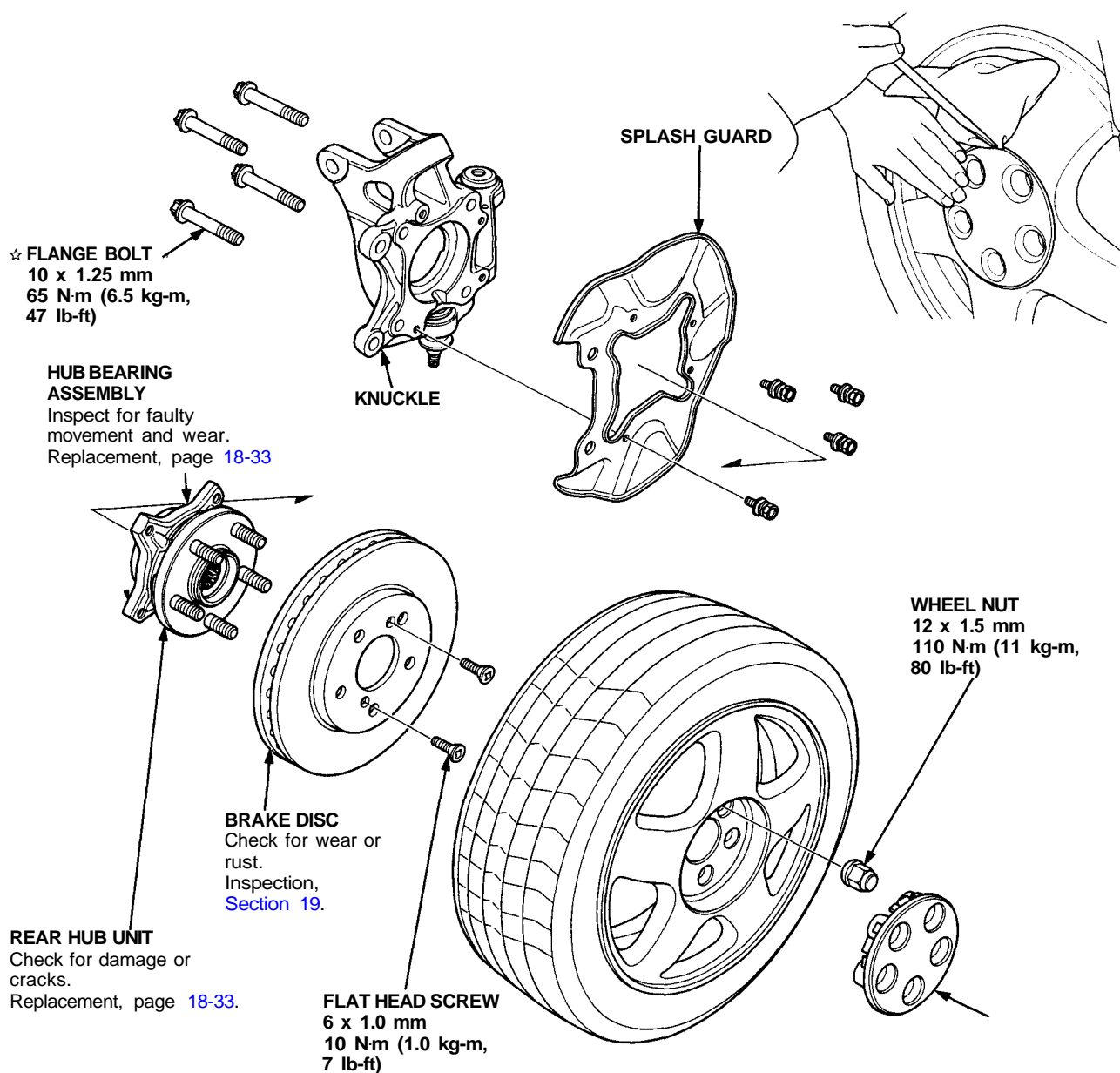

Hub Replacement

NOTE:

- Use only genuine Honda wheel weights for aluminum wheels. Non-genuine wheel weights may corrode and damage the aluminum wheels.
- Remove the center cap by prying it out with a flat screwdriver. Use a rag at the point you are going to pry, because aluminum alloy wheels can be easily damaged. Avoid damage to the cap by not allowing it to fall during removal.
- Before installing the brake disc, clean the mating surface of the rear hub and inside of the brake disc.
- Before installing the wheel, clean the mating surfaces of the brake disc and inside of the wheel.



☆: Corrosion resistant bolt/nut

Rear Suspension

Hub Replacement

1. Remove the center cap, then pry the spindle nut lock tab away from the spindle and loosen the nut.
2. Raise the car and support it with safety stands (see section 1).

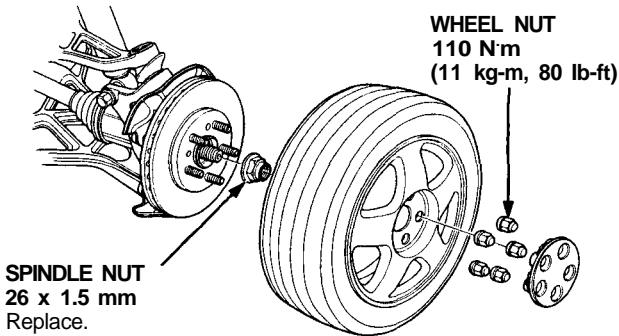

3. Remove the rear wheels.

NOTE: Before installing the wheel, clean the mating surfaces of the brake disc and inside of the wheel.

4. Remove the spindle nut.
5. Remove the wheel sensor from the knuckle and rear lower control arm.

NOTE:

- Do not disconnect the wheel sensor.
- Be careful when installing the sensors to avoid twisting wires.

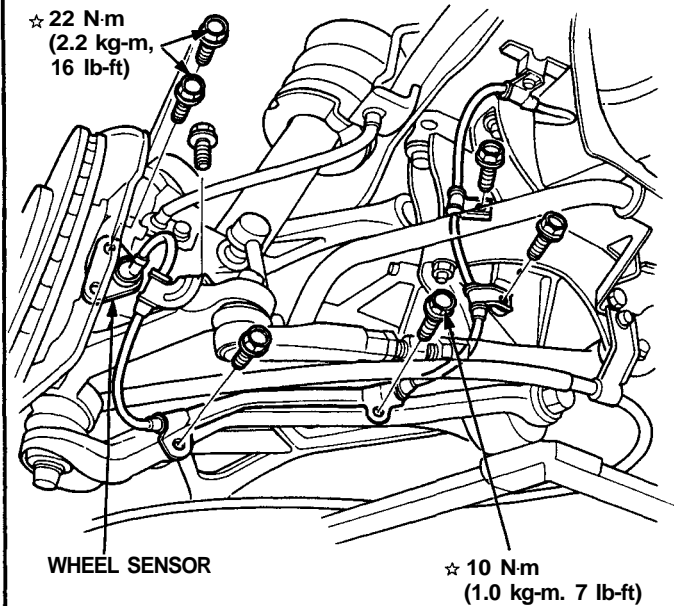

☆: Corrosion resistant bolt/nut

6. Remove the banjo bolt and disconnect the brake hose, then remove the brake hose clamp from the knuckle.

CAUTION: Avoid spilling brake fluid on painted, plastic or rubber surfaces as it can damage the finish;
Wash spilled brake fluid off immediately with clean water.

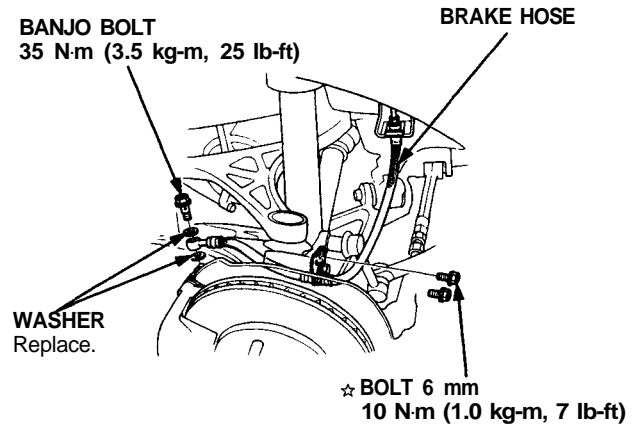

☆: Corrosion resistant bolt/nut

7. Remove the rear caliper by removing the mounting bolts.

☆ **CALIPER BRACKET MOUNTING BOLT**
110 N-m (11 kg-m, 80 lb-ft)

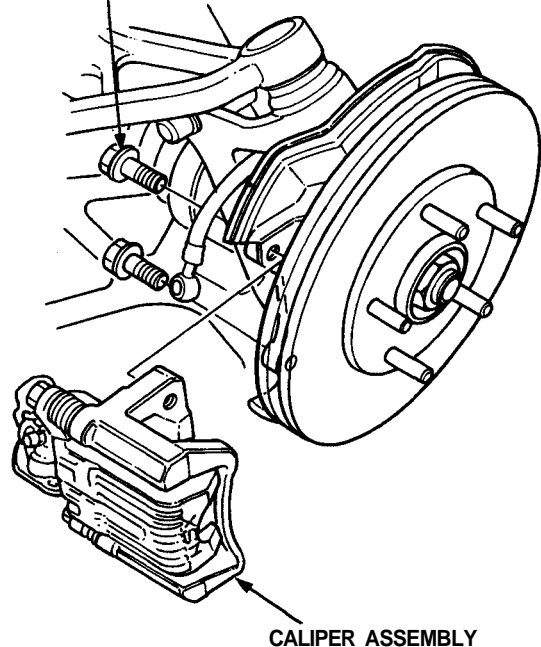

☆: Corrosion resistant bolt/nut



- Remove the flat head screws.
Screw two 8 x 12 mm bolts into the disc to push it away from the hub.

NOTE: Turn each bolt two turns at a time to prevent cocking the disc excessively.

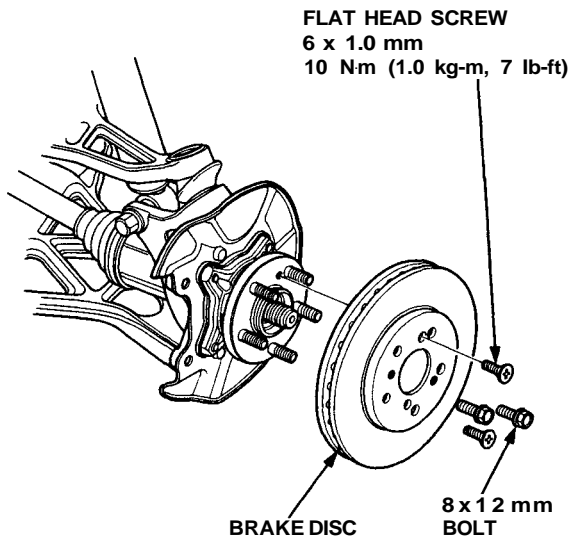

- Remove the rear hub unit from the knuckle.

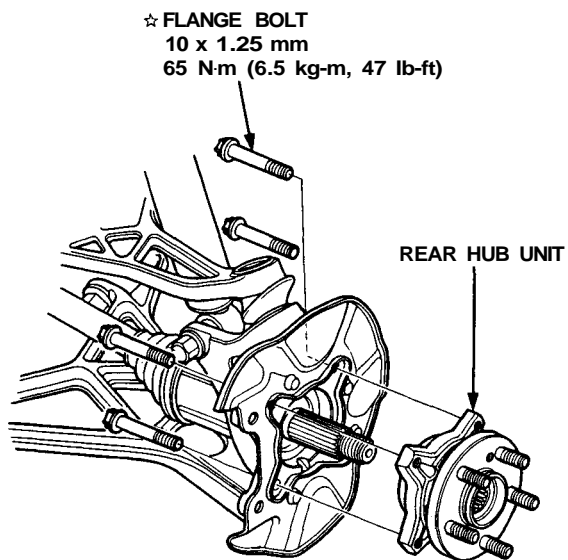

☆: Corrosion resistant bolt/nut

Rear Wheels Bearing Replacement:

- Separate the wheel bearing from the hub using the special tools and a press.

CAUTION: Hold onto the hub to keep it from falling when pressed clear.

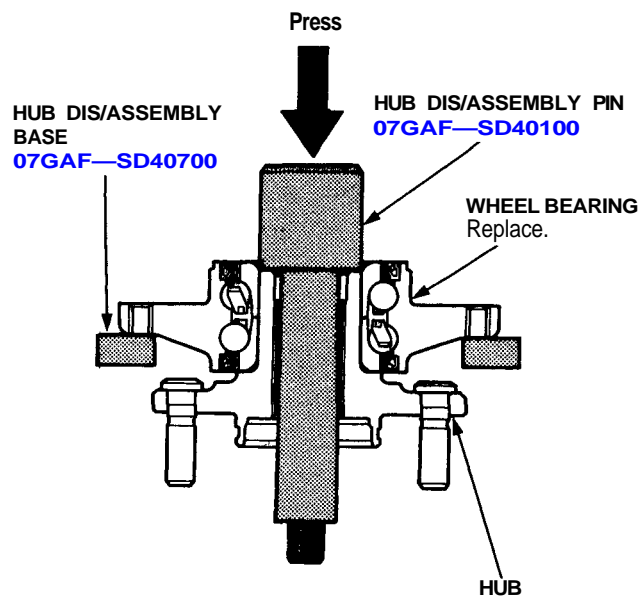

- Remove the wheel bearing inner race from the hub using a commercially available bearing puller.

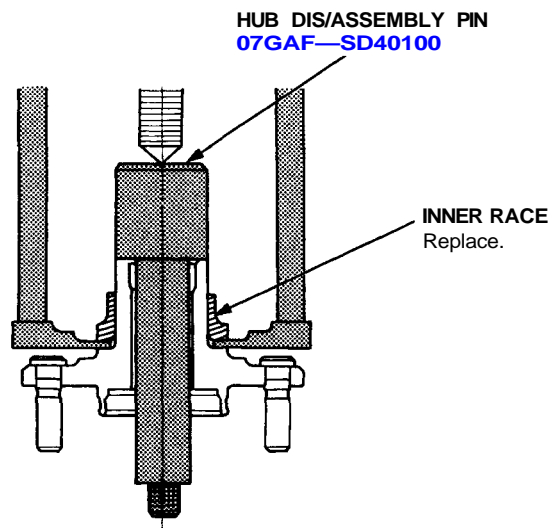

NOTE: Wash the bearing and hub thoroughly in high flash point solvent before reassembly.

(cont'd)

Rear Suspension

Hub Replacement (cont'd)

NOTE: Replace the bearing with a new one after removal.

3. Press a new wheel bearing into the hub using the special tools and a press.

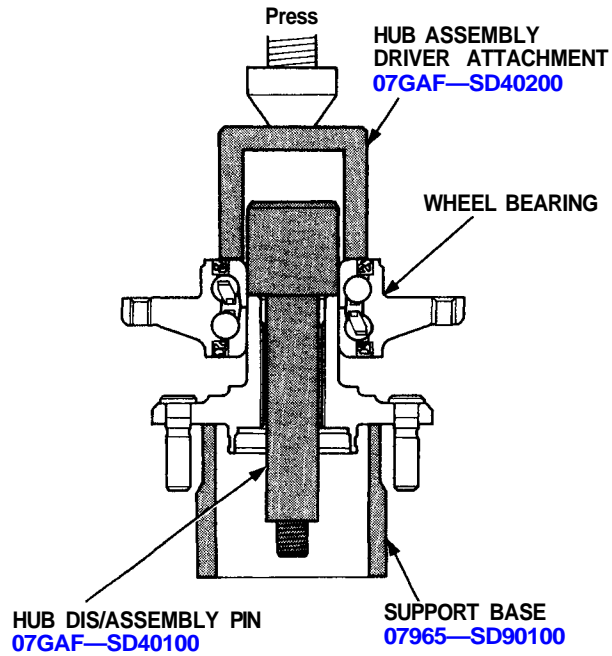

4. Install the hub in reverse order of removal.