

EPS Control unit

Replacement

⚠ WARNING All SRS wire harnesses and connectors are colored yellow. Do not use electrical test equipment on these circuits.

CAUTION: Be careful not to damage the SRS wire harnesses when servicing the control unit.

1. Remove the dashboard lower cover and glove box and disconnect the light connector.

GLOVE BOX

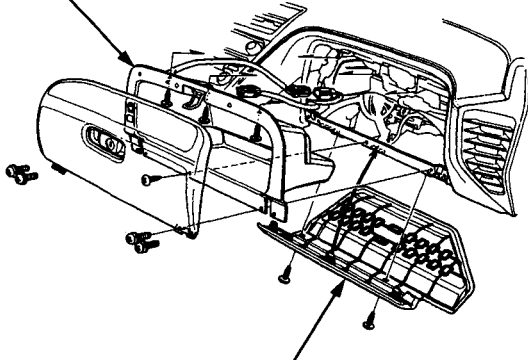

DASHBOARD LOWER COVER

2. Move the heater duct right then remove the heater duct.

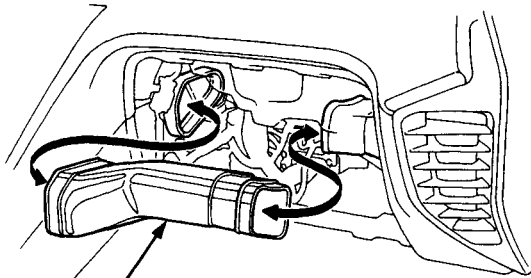

HEATER DUCT

3. Disconnect the connectors from the EPS control unit by removing the wire harness band.

EPS CONTROL UNIT

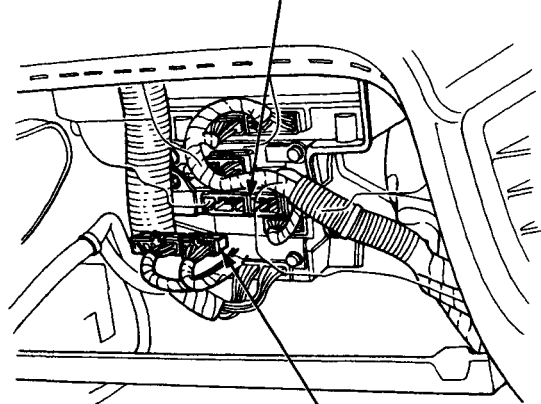

CONNECTORS

4. Remove the power window control unit by pulling it toward you, then remove the EPS control unit.

EPS CONTROL UNIT

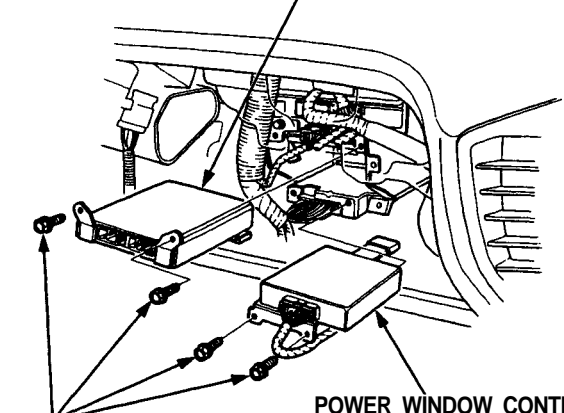

10 Nm
(1.0 kg-m, 7 lb-ft)

POWER WINDOW CONTROL UNIT

5. Installation is the reverse of the removal procedure.

NOTE: Turn the ignition switch ON and check the EPS indicator light for operation.