



# Transmission

## Reassembly

NOTE: Coat all parts with ATF.

1. Reassemble the valve bodies in the following numbered sequence.

**CAUTION:** To prevent stripping the threads, press down on the accumulator cover while installing the bolts.

### TORQUE:

6 x 1.0 mm: all bolts except ⑤⑩: 12 N·m (1.2 kg-m, 9 lb-ft)

6 x 1.0 mm: ⑤⑩: 14 N·m (1.4 kg-m, 10 lb-ft)

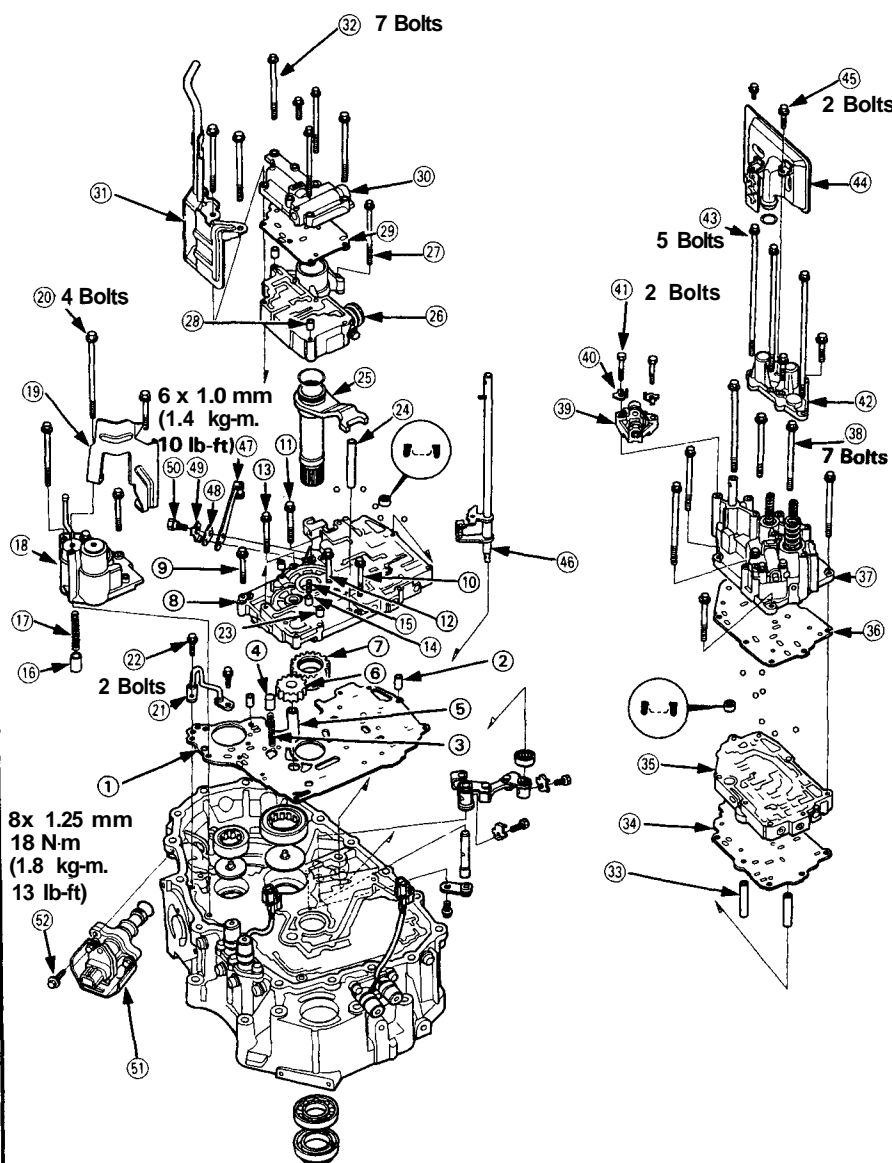

NOTE: Install the oil pump driven gear with its chamfered side facing down.

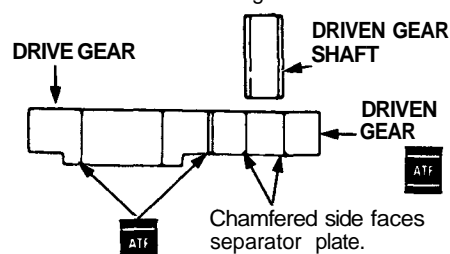

NOTE: Make sure the pump drive gear rotates smoothly in the normal operating direction and the pump shaft moves smoothly in the axial and normal operating directions.

**CAUTION:** If the pump gear and pump shaft do not move freely, loosen the valve body bolts, realign the shaft, and then retighten to the specified torque. Failure to align the pump shaft correctly will result in seized pump gear or pump shaft.

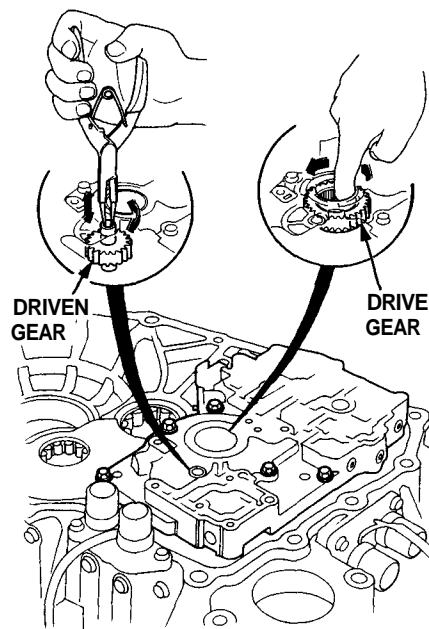

(cont'd)

# Transmission

## Reassembly (cont'd)

2. Assemble the transmission housing in the following numbered sequence.

NOTE: See page 14-145 when installing the reverse idler gear.

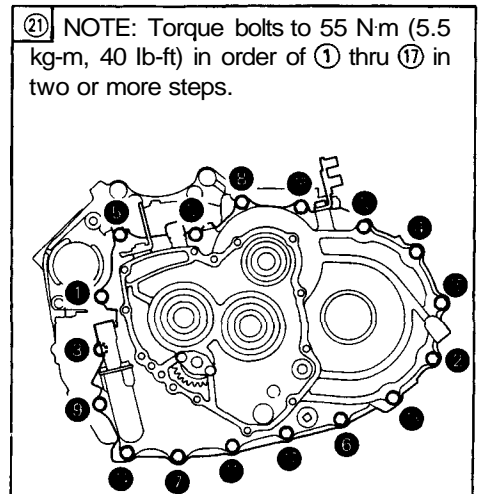
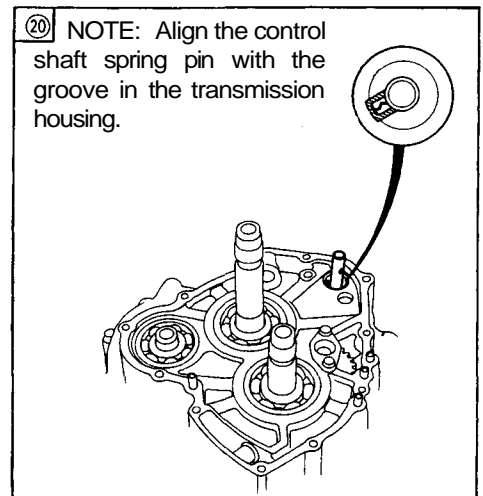
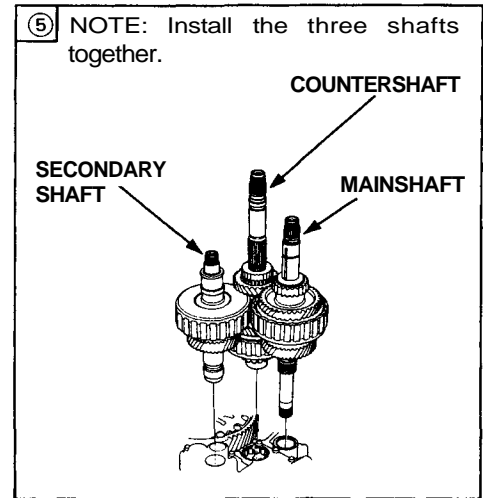
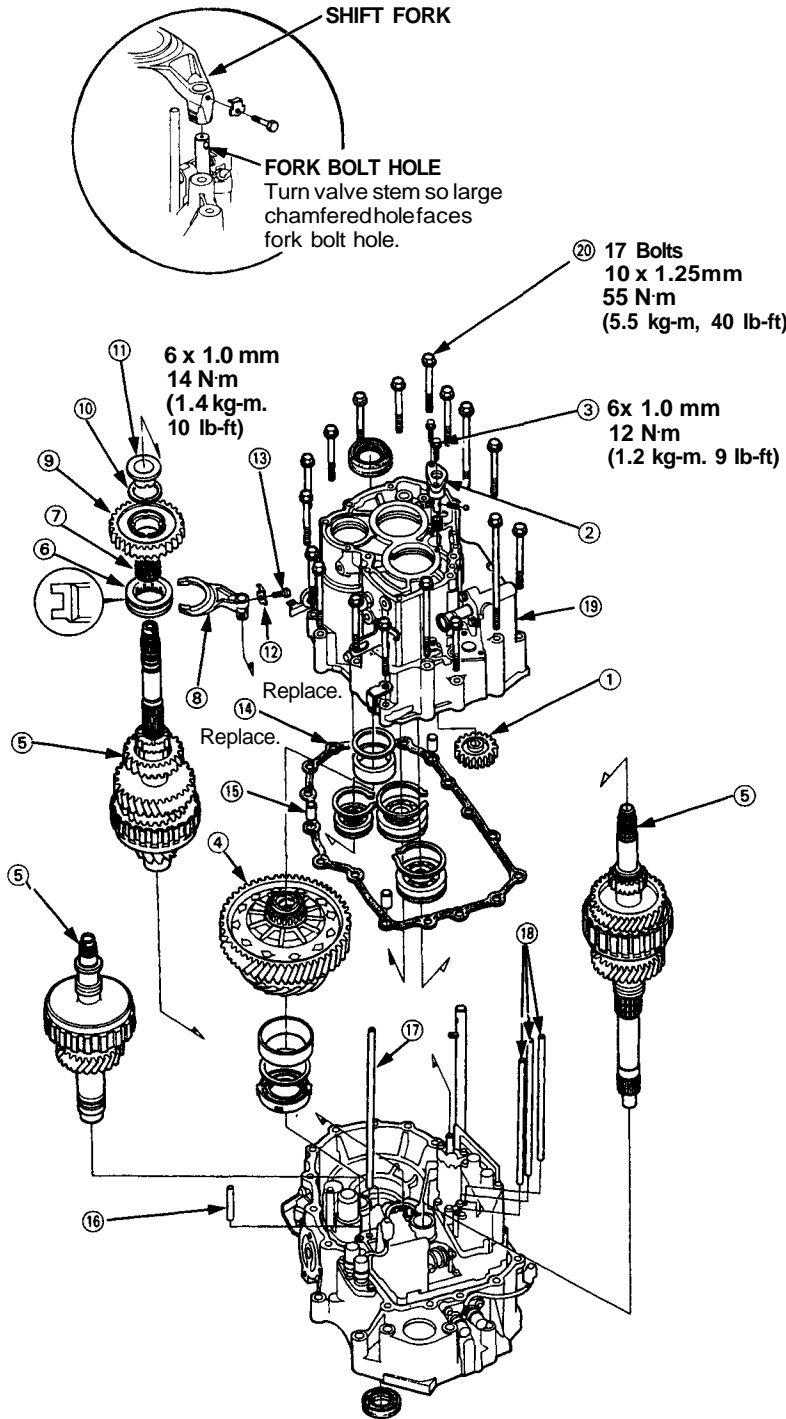



3. Assemble the transmission in the following numbered sequence.

NOTE: Before installing the O-rings, wrap the shaft splines with tape to prevent damage to the O-rings.

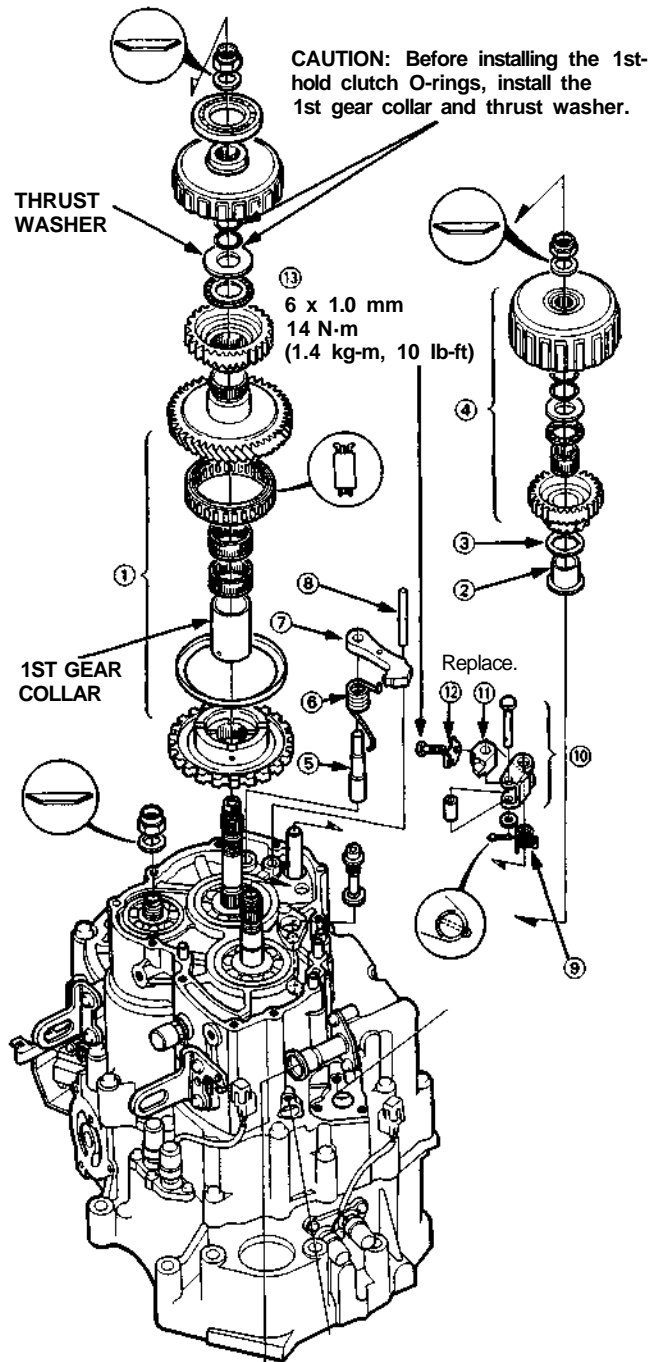

4. Set the parking brake lever in the **P** position, then verify that the parking brake pawl engages the parking gear.
5. If the pawl does not engage fully, check the parking brake pawl stopper clearance as described on page 14-146.
6. Tighten the lock bolt and bend over the lock tab.

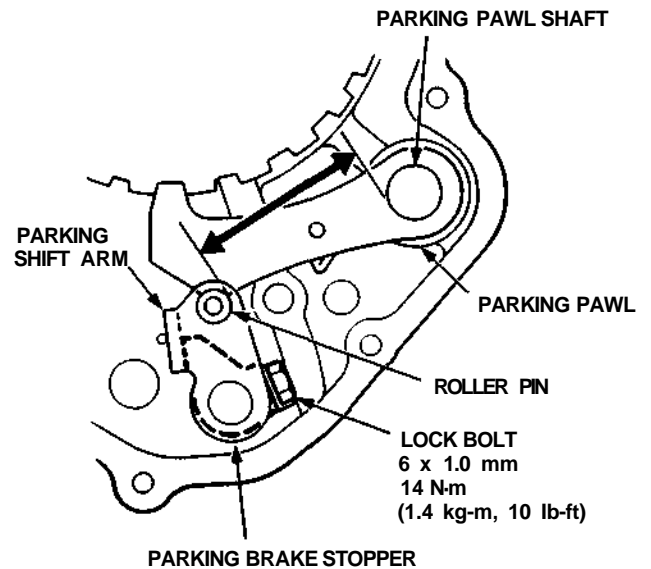

7. Install the special tool as shown, and shift to **P** position.

MAINSHAFT HOLDER  
07924-PJ4010A

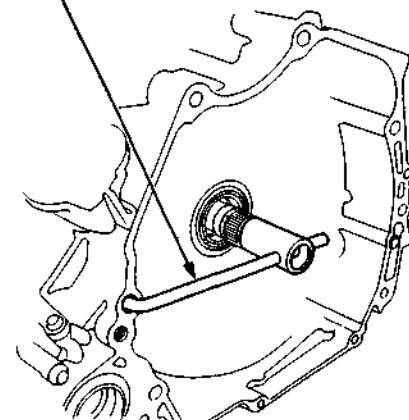

(cont'd)

# Transmission

## Reassembly (cont'd)

8. Install a new conical spring washers and new locknuts on each shaft.

**CAUTION:** Install the conical spring washers in the direction shown.

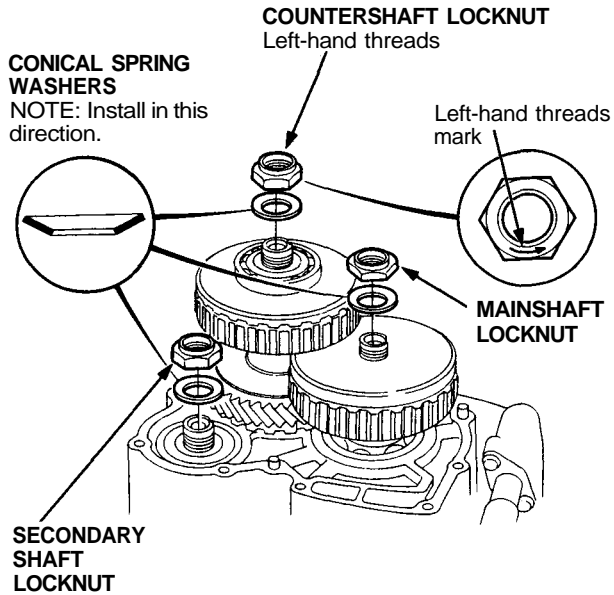

9. Tighten the locknuts to specified torque.

**TORQUE: 140 N·m (14.0 kg·m, 101 lb·ft)**

**NOTE:** Countershaft locknut has left-hand threads.

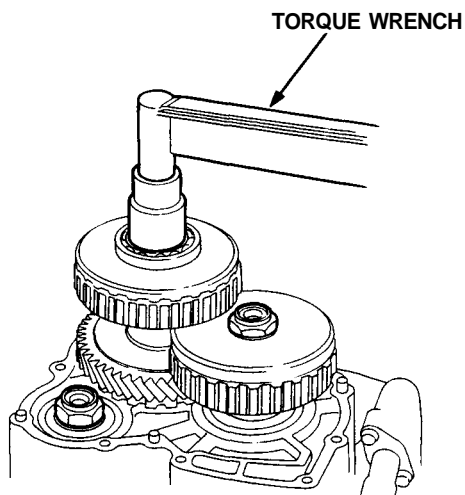

10. Stake each locknut into its shaft, using a 3.5 mm punch.

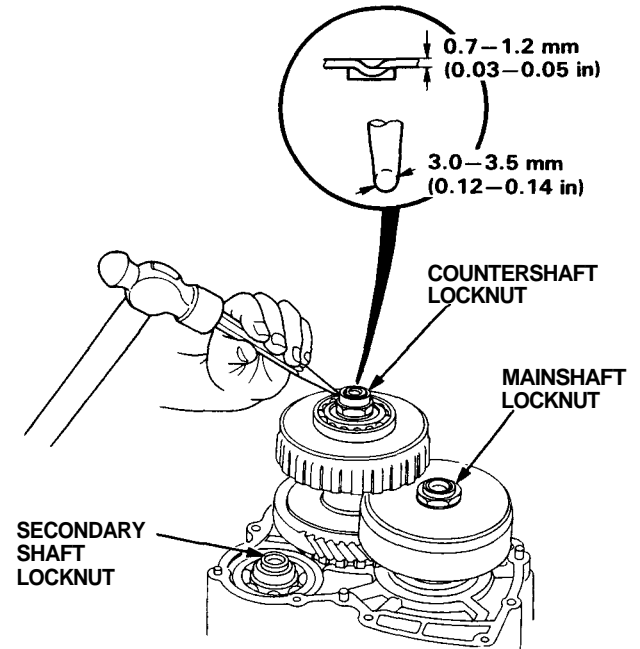

11. Install the feed pipes and ball bearing in the left side cover, aligning the lugs of the 1st and 1st-hold clutch feed pipes with the grooves of the left side cover.

12. Install the snap ring.

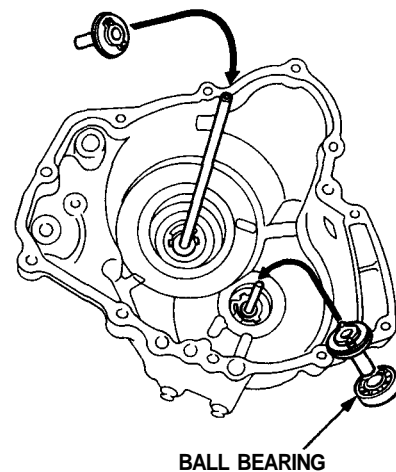



12. Install the left side cover.

**TORQUE: 12 N·m (1.2 kg·m, 9 lb·ft)**

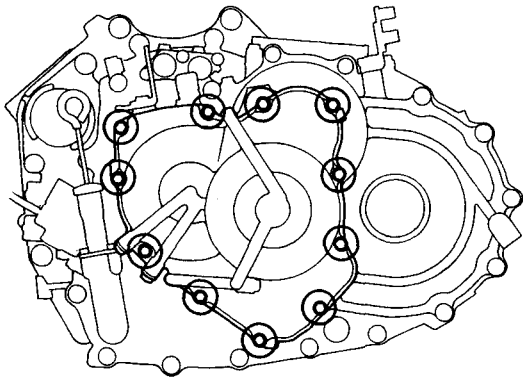

13. Install the countershaft and mainshaft speed sensors, vehicle speed sensor cover and linear solenoid.

**TORQUE: 12 N·m (1.2 kg·m, 9 lb·ft)**

NOTE:

- Install the countershaft speed sensor with the countershaft speed sensor washer. The mainshaft speed sensor has no washer.
- See page 14-81 thru 82, when installing the linear solenoid.

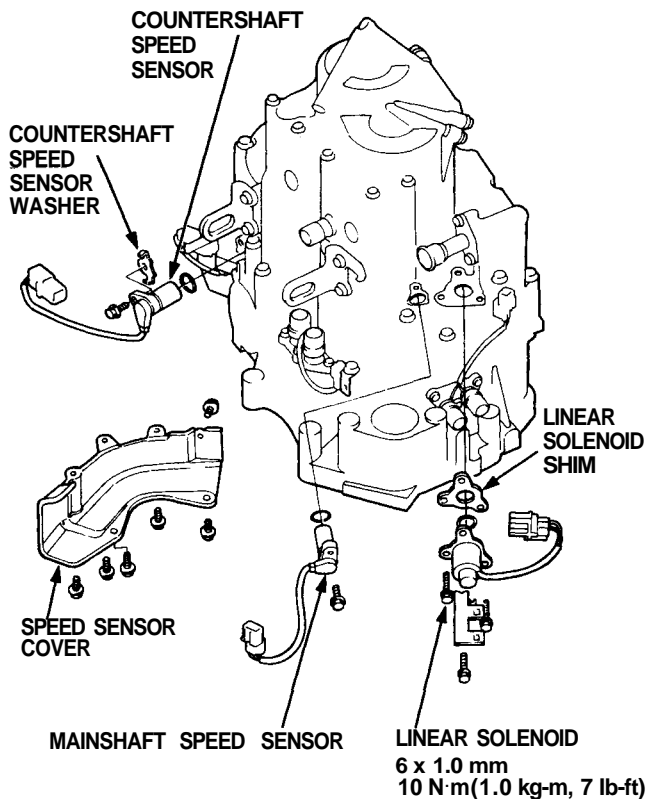

14. Install the control lever, new lock washers, change shaft and change shaft cap on the other end of the control shaft. Tighten the bolts and then bend the tab over against the bolt head.

