



## Reassembly

### NOTE:

- Clean all parts thoroughly in solvent or carburetor cleaner, and dry with compressed air.
- Blow out all passages.
- Lubricate all parts with ATF before assembly.

1. Inspect for a loose check valve.

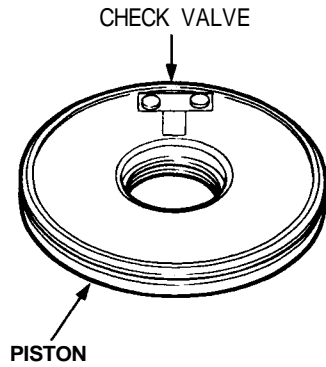

2. Install a new O-ring on the clutch piston.
3. Be sure that the disc spring is securely staked.

NOTE: For 1st, 3rd and 4th clutches.

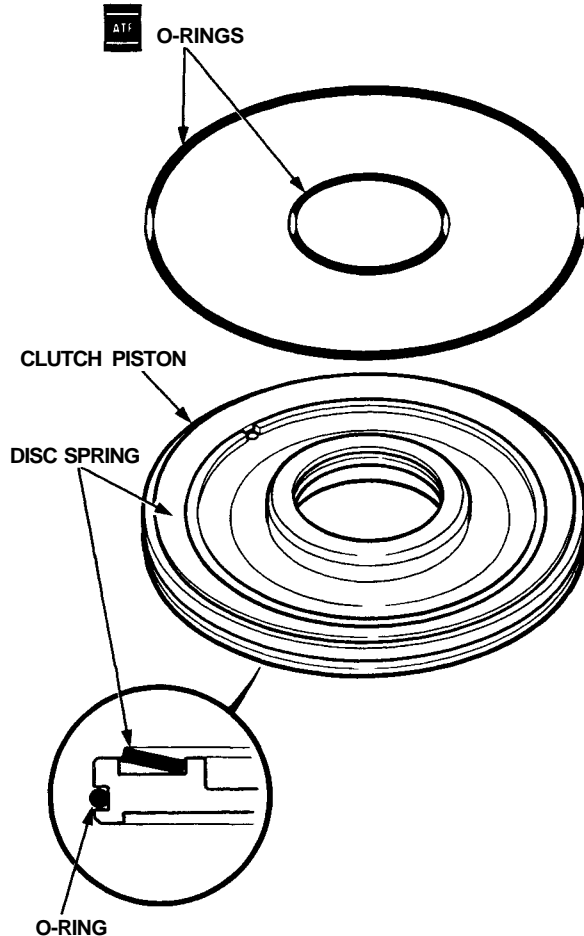

4. Install the piston in the clutch drum. Apply pressure and rotate to ensure proper seating.

NOTE: Lubricate the piston O-ring with ATF before installing.

**CAUTION: Do not pinch O-ring by installing the piston with force.**

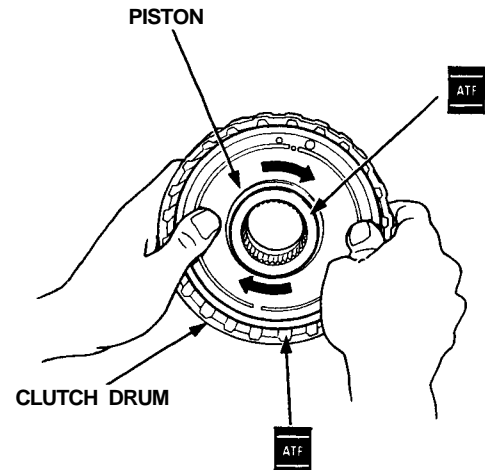

5. Install the return spring and spring retainer and position the circlip on the retainer.

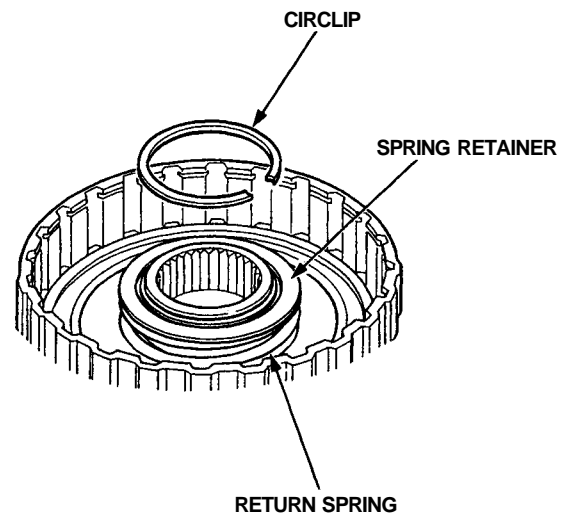

(cont'd)

# Clutch

## Reassembly (cont'd)

6. Install the special tools as shown.

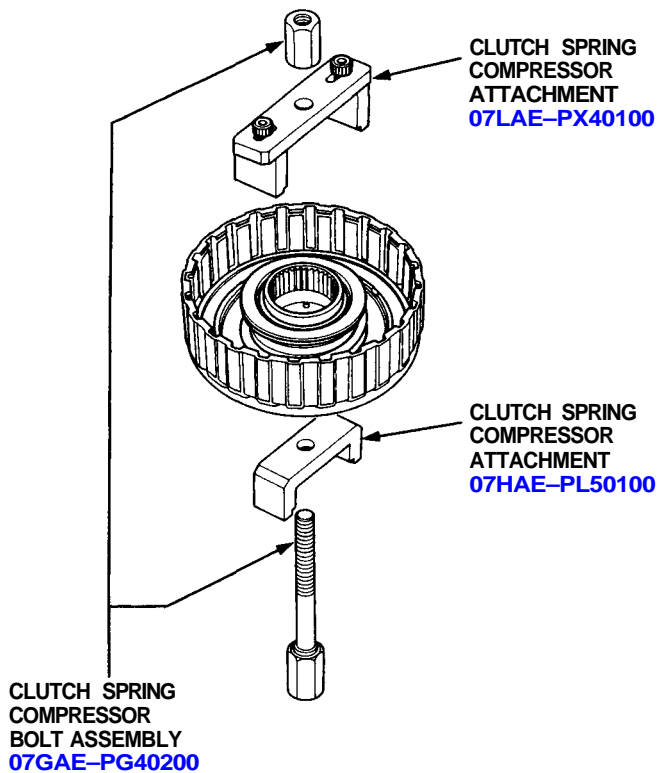

**CAUTION:** If either end of the compressor attachment is set over an area of the spring retainer which is unsupported by the retainer spring, the retainer may be damaged.

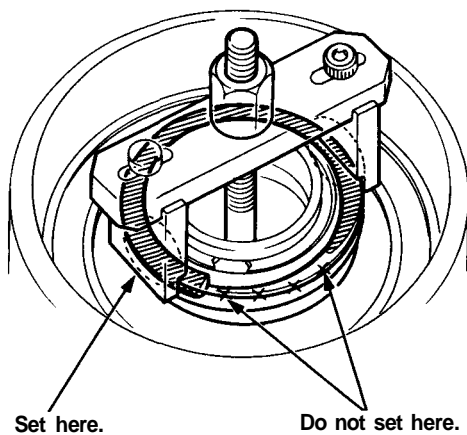

7. Compress the clutch return spring.

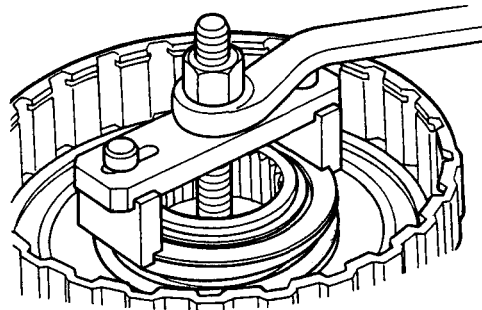

8. Install the circlip.

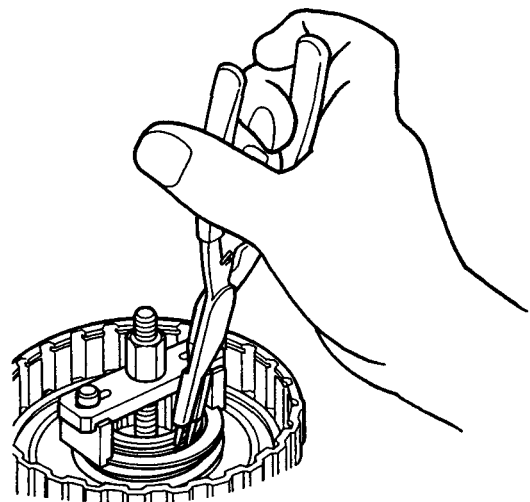

9. Remove the special tools.



10. Install the disc spring.

NOTE:

- For 1st-hold and 2nd clutches
- Install the disc spring in the direction shown.

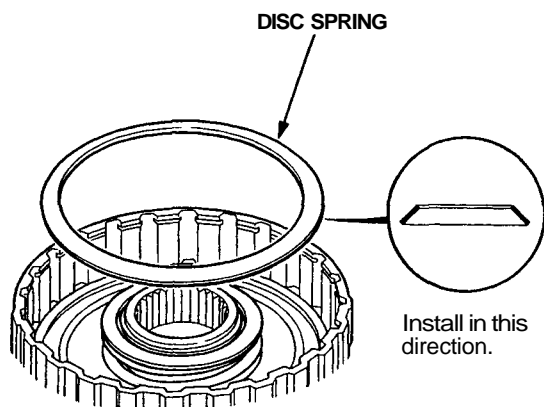

11. Soak the clutch discs thoroughly in ATF for a minimum of 30 minutes.

12. Starting with a clutch plate, alternately install the clutch plates and discs. Install the clutch end plate with flat side toward the disc.

NOTE: Before installing the plates and discs, make sure the inside of the clutch drum is free of dirt or other foreign matter.

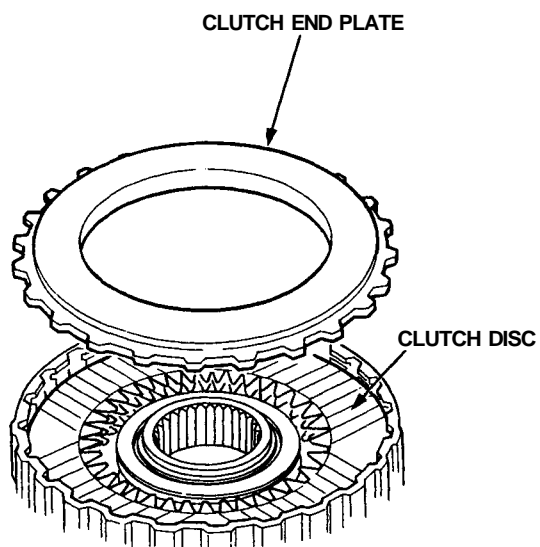

13. Install the snap ring

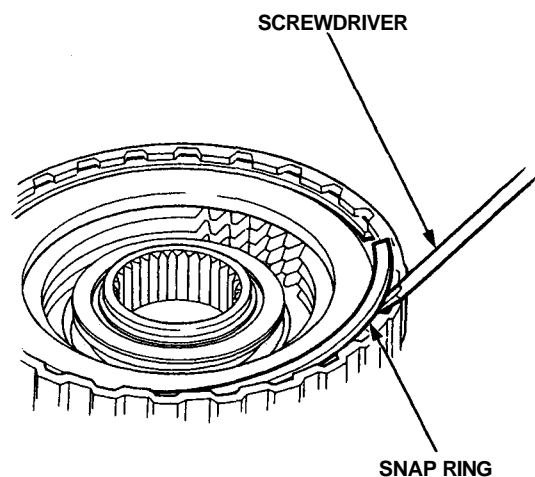

(cont'd)

# Clutch

## Reassembly (cont'd)

14. Measure the clearance between the clutch end plate and top disc with a dial indicator. Zero the dial indicator with the clutch end plate lowered and lift it up to the snap ring. The distance that the clutch end plate moves is the clearance between the clutch end plate and top disc.

NOTE: Measure at three locations.

### End Plate-to-Top Disc Clearance:

Clutch	Service Limit
1st	0.65 – 0.85 mm (0.026 – 0.033 in)
2nd	0.75 – 0.95 mm (0.030 – 0.037 in)
3rd	0.75 – 0.95 mm (0.030 – 0.037 in)
4th	0.75 – 0.95 mm (0.030 – 0.037 in)
1st-Hold	0.70 – 0.90 mm (0.028 – 0.035 in)

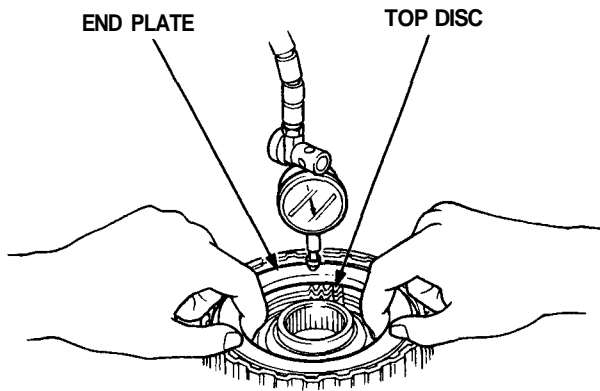

15. If the clearance is not within the service limits, select a new clutch end plate from the following table.

NOTE: If the thickest clutch end plate is installed but the clearance is still over the standard, replace the clutch discs and clutch plates.

### 2ND, 3RD, 4TH and 1ST HOLD CLUTCH

Part Number	Plate No.	Thickness mm (in)
22551-PX4-003	1	2.1 (0.083)
22552-PX4-003	2	2.2 (0.087)
22553-PX4-003	3	2.3 (0.091)
22554-PX4-003	4	2.4 (0.094)
22555-PX4-003	5	2.5 (0.098)
22556-PX4-003	6	2.6 (0.102)
22557-PX4-003	7	2.7 (0.106)
22558-PX4-003	8	2.8 (0.110)
22559-PX4-003	9	2.9 (0.114)

### 1ST CLUTCH

Part Number	Plate No.	Thickness mm (in)
22631-PR9-003	1	2.1 (0.083)
22632-PR9-003	2	2.2 (0.087)
22633-PR9-003	3	2.3 (0.091)
22634-PR9-003	4	2.4 (0.094)
22635-PR9-003	5	2.5 (0.098)
22636-PR9-003	6	2.6 (0.102)
22637-PR9-003	7	2.7 (0.106)
22638-PR9-003	8	2.8 (0.110)
22639-PR9-003	9	2.9 (0.114)

