

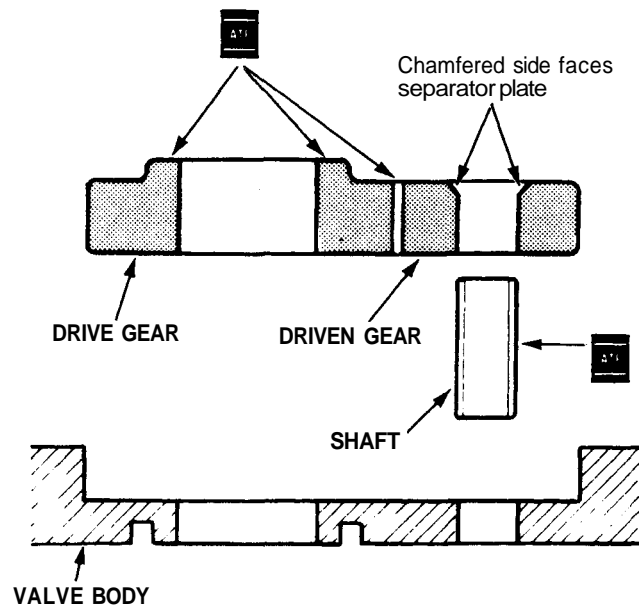

Oil Pump

Inspection

1. Install the pump gears and shaft in the main valve body.



2. Measure the side clearance of the drive and driven gears.

Pump Gears Side (Radial) Clearance:

Standard (New): Drive gear (diameter)

0.210–0.265 mm

(0.0083–0.0104 in)

Driven gear (radius)

0.035–0.063 mm

(0.0014–0.0025 in)

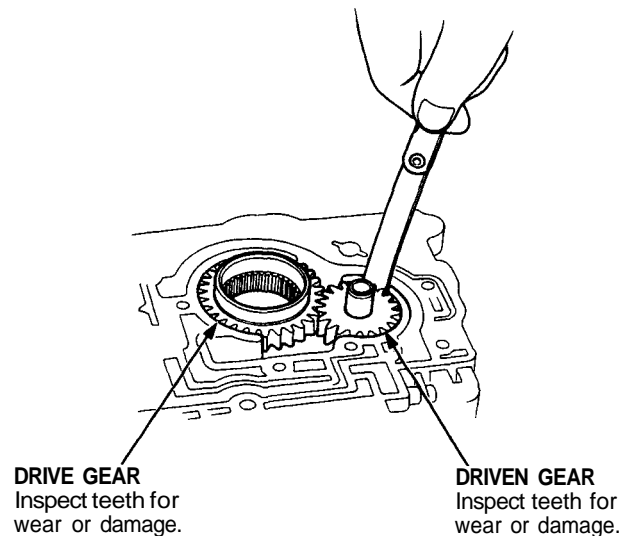

3. Remove the shaft then measure the thrust clearance of the driven gear-to-valve body.

Drive/Driven Gear thrust (Axial) Clearance:

Standard (New): 0.03–0.05 mm

(0.001–0.002 in.)

Service Limit: 0.07 mm (0.0028 in.)

