

Transmission Housing

Removal

NOTE: Place the clutch housing on two pieces of wood thick enough to keep the mainshaft from hitting the workbench.

1. Remove the back-up light switch, neutral position switch and vehicle speed sensor (VSS).

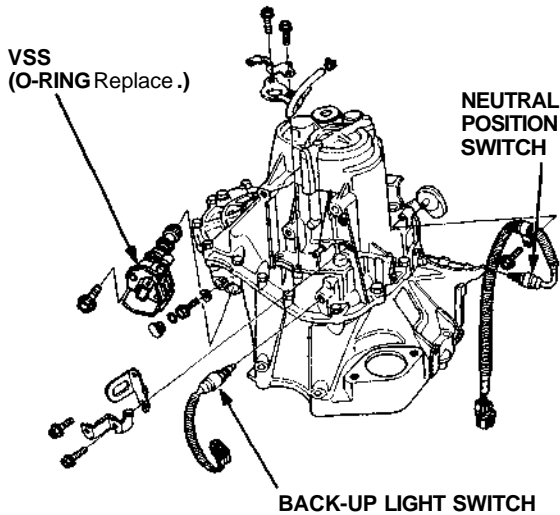

2. Remove the sealing bolts, springs and steel balls.
3. Remove the transmission housing attaching bolts in a criss-cross pattern in several steps.
4. Remove the 36 mm sealing bolt.

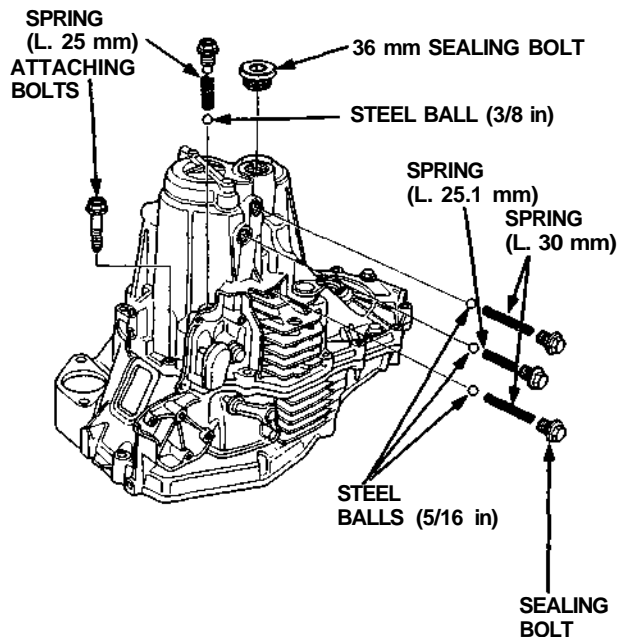

5. Expand the snap ring on the countershaft ball bearing and remove it from the groove using a pair of snap ring plier.

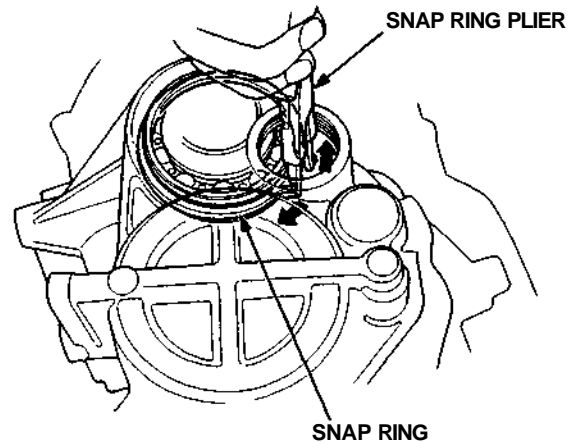

6. Separate the clutch housing from the transmission housing.
7. Remove the thrust shim and oil guide plate from the transmission housing.

