



Cylinder Heads

Valve Installation

NOTE: Tap the valve stem only along its axis so you do not bend the stem.

- When installing valves in cylinder head, coat valve stems with oil before inserting into valve guides, and make sure valves move up and down smoothly.
- When valves and springs are in place, lightly tap the end of each valve stem two or three times to ensure proper seating of valve and valve keepers (use hammer handle bottom).

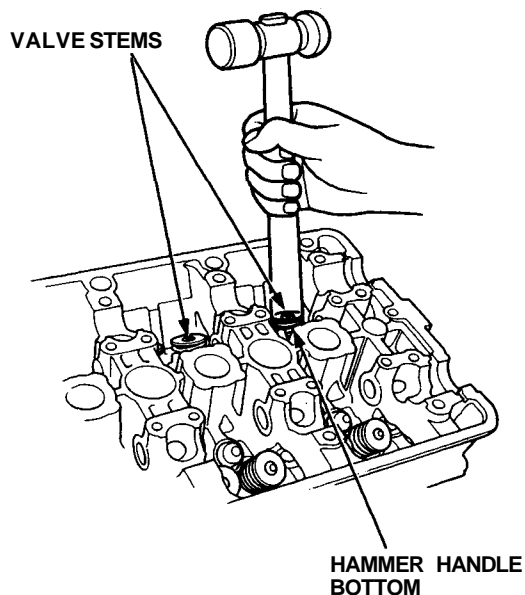

Installation

Install the cylinder heads in the reverse order of removal:

- Always use new head gaskets.
 - Cylinder heads and engine block surface must be clean.
 - Turn the crankshaft so that No. 1 piston is at TDC (page 6-26).
1. Install the front and rear exhaust manifolds to each cylinder head, then tighten the self-locking nuts in a criss-cross pattern in two or three steps, beginning with the inner nut.
 - Apply oil to the self-locking nut threads.
 - Always use new exhaust manifold gaskets.

2. Install the exhaust manifold covers.

Front:

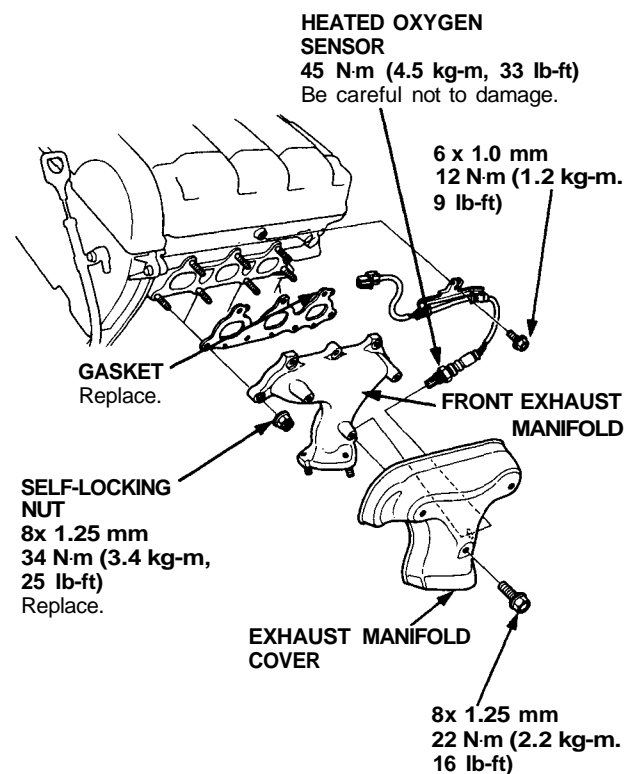

(cont'd)

Cylinder Heads

Installation (cont'd)

Rear:

8 x 1.25 mm
22 N·m (2.2 kg·m,
16 lb-ft)

**HEATED OXYGEN
SENSOR**
45 N·m (4.5 kg·m,
33 lb-ft)
Be careful not to damage.

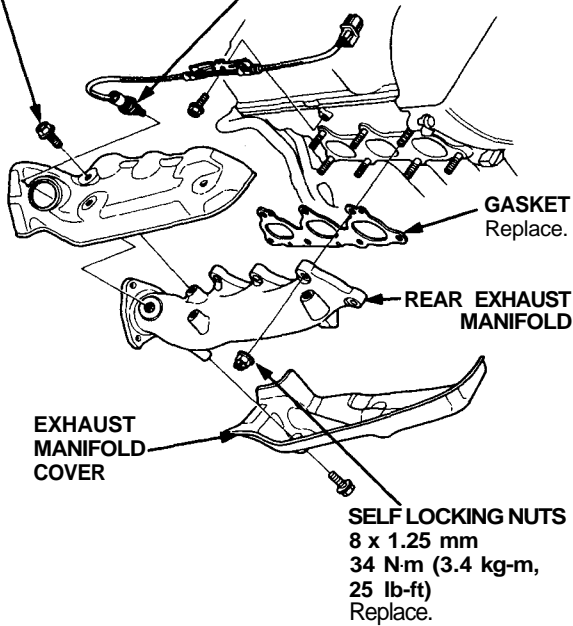

GASKET
Replace.

**REAR EXHAUST
MANIFOLD**

**EXHAUST
MANIFOLD
COVER**

SELF LOCKING NUTS
8 x 1.25 mm
34 N·m (3.4 kg·m,
25 lb-ft)
Replace.

3. Install the cylinder heads on the engine block. The cylinder head dowel pins and the head oil control orifice must be aligned.
 - Always use a new cylinder head gasket.

**CYLINDER HEAD
GASKET (METAL)**
Replace.

**CYLINDER HEAD
GASKET (METAL)**
Replace.

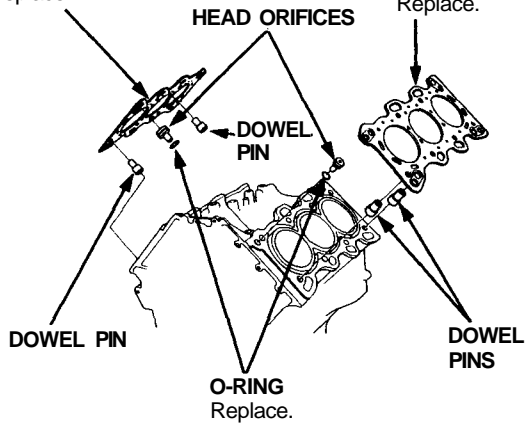

HEAD ORIFICES

**DOWEL
PIN**

DOWEL PIN

O-RING
Replace.

**DOWEL
PINS**

4. Tighten the cylinder head bolts sequentially in two or three steps.
 - Apply clean engine oil to the bolt threads and washer contact surfaces.

Specified Torque

11 x 1.5 mm

78 N·m (7.8 kg·m, 56 lb-ft)

NOTE: We recommend using a beam-type torque wrench. When using a preset-type torque wrench, be sure to tighten slowly and not to over-tighten.

CYLINDER HEAD BOLTS TORQUE SEQUENCE

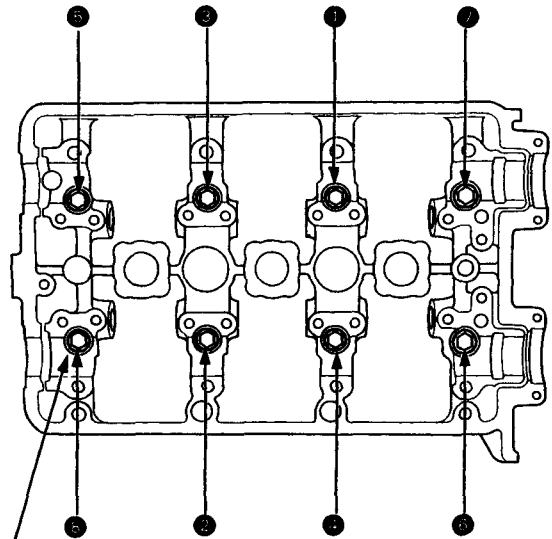

CYLINDER HEAD BOLTS

11 x 1.5 mm

78 N·m (7.8 kg·m, 56 lb-ft)

Apply clean engine oil to the bolt threads and washer contact surfaces.