

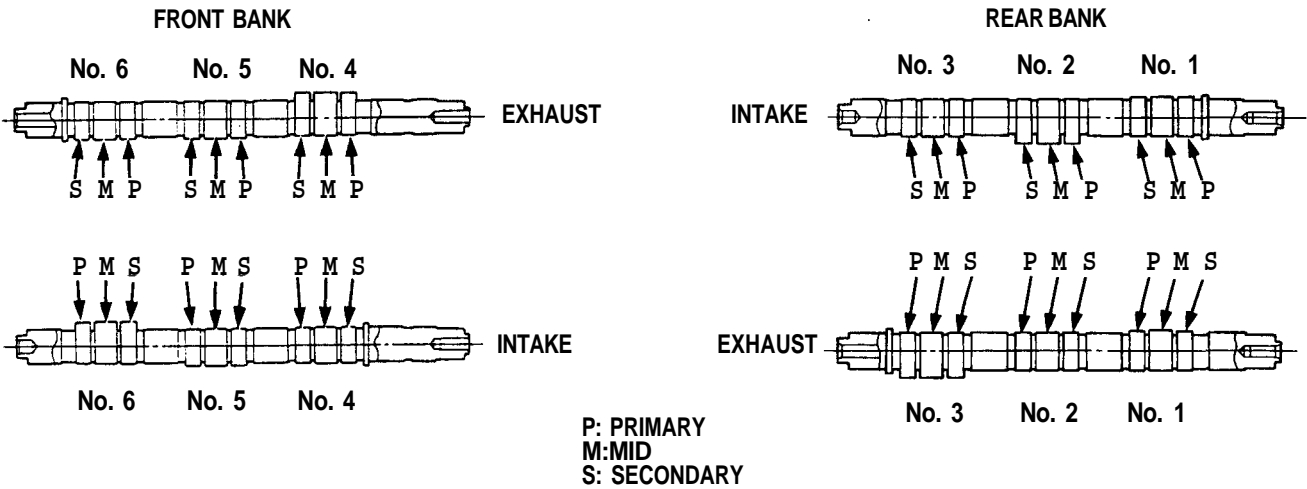

Cylinder Head

Camshaft

The camshaft is a cast piece. By improving dimensional accuracy, it became possible to achieve minimum space between cams, thus allowing a more compact cylinder head. Each camshaft is supported on four bearing journals with forced lubrication. On the right end of each camshaft is a driven pulley. The exhaust and intake cycles require a total of 36 cam lobes to open and close the valves.



Manual Transmission

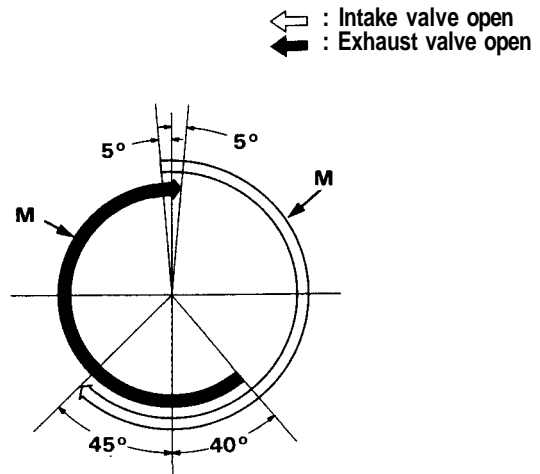
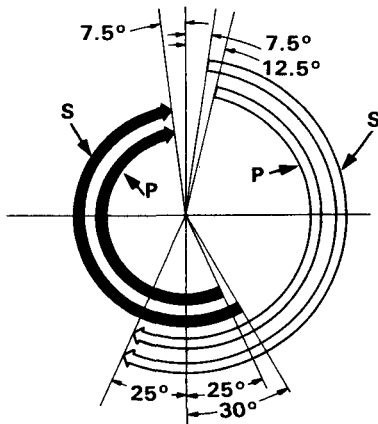

Automatic Transmission

