

Wipers/Washers

Windshield Wiper Motor Replacement

1. Open the hood, and remove the cap nuts and the wiper arms. Don't let the wiper arms hit the hood.
2. Remove the windshield lower molding, hood seal and air scoop by prying off the trim clips and removing the screws (see page 23-293 ('94-'96) ('93) ('91-'92)).
3. Disconnect the 5-P connector from the wiper motor assembly, then remove the two mounting bolts and the wiper linkage assembly.

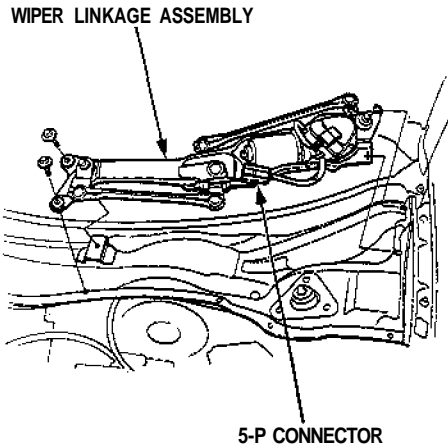

4. Remove the three mounting bolts and nut from the wiper linkage assembly, and remove the wiper motor.

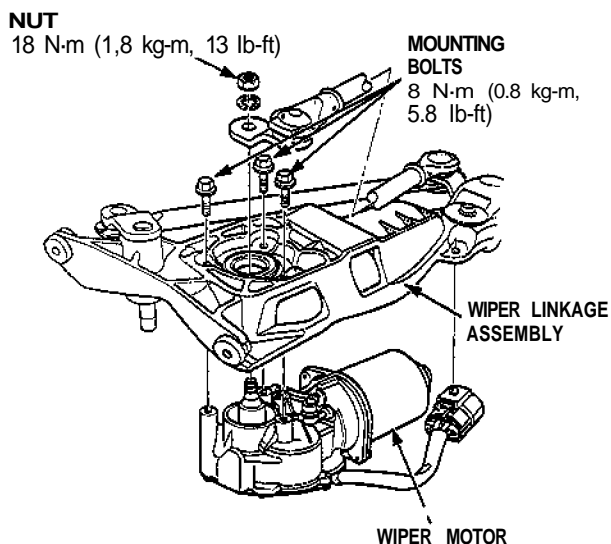

5. Install the wiper motor assembly in the reverse order of removal.

Windshield Wiper/Washer Switch Replacement

SRS components are located in this area. Review the SRS component locations, precautions, and procedures in the SRS section (24) before performing repairs or service.

1. Remove the dashboard lower cover, and disconnect the connectors.
2. Remove the dashboard lower pad.

