

Interlock System

Shift Lock Solenoid Test/Replacement

Test:

1. Remove the console, then disconnect the 3-P connector of the shift lock solenoid from the floor wire harness.

NOTE: This solenoid has a diode in it. To get an accurate reading, either test it with a volt-ohmmeter that compensates for diodes, or make sure you connect your test leads to match the polarity shown.

2. Connect battery power to the A terminal and ground to the B terminal momentarily, and check to see if the solenoid works.

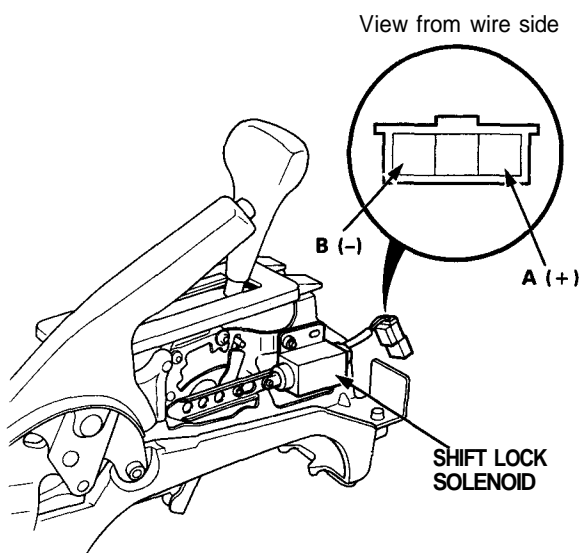

- If it does not work, replace it.
- If it works, go to step 3.

3. When the shift lock solenoid is ON, check that there is a clearance of 2.5 ± 0.5 mm (0.098 ± 0.020 in) between the top corner of the shift lock lever and the side of the lock pin.

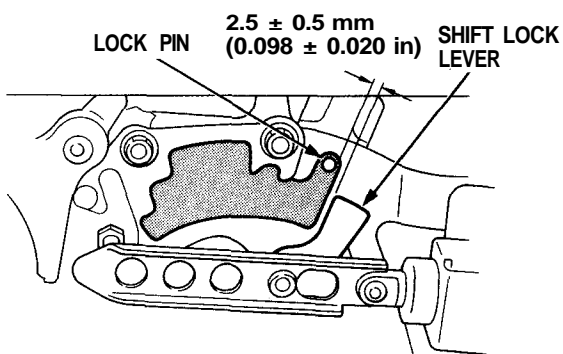

- If clearance is correct, go to next step.
- If clearance is incorrect, loosen the self-locking nuts and adjust the solenoid as needed.

4. When the shift lock solenoid is OFF, make sure that the lock pin is blocked by the top of the shift lock lever.

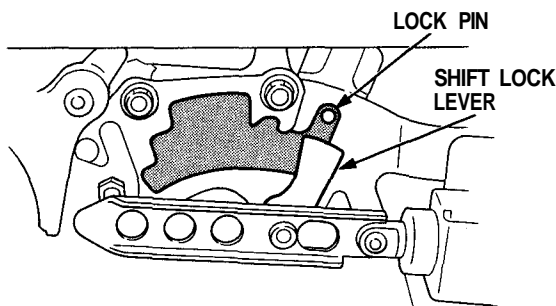

If it is not blocked, adjust the position of the shift lock solenoid as needed to block it.

Replacement:

1. Remove the E ring and the solenoid pin.

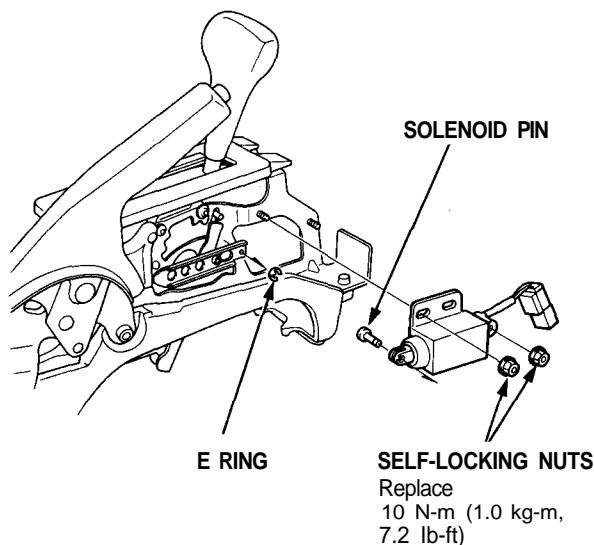

2. Remove the self-locking nuts and shift lock solenoid.
3. Install the new shift lock solenoid in the reverse order of removal.
4. Check the position of the shift lock solenoid as described in steps 3 and 4.