



# Alternator Belt Adjustment

## Deflection Method:

1. Apply a force of 100 N (10kg, 22 lbs) between the alternator and crankshaft pulley, and measure its deflection.

**Deflection: 11-13.5 mm (0.43-0.53 in)**

NOTE: On a brand-new belt, the deflection should be 6-8 mm (0.24-0.31 in) before the belt has had any running time on the engine.

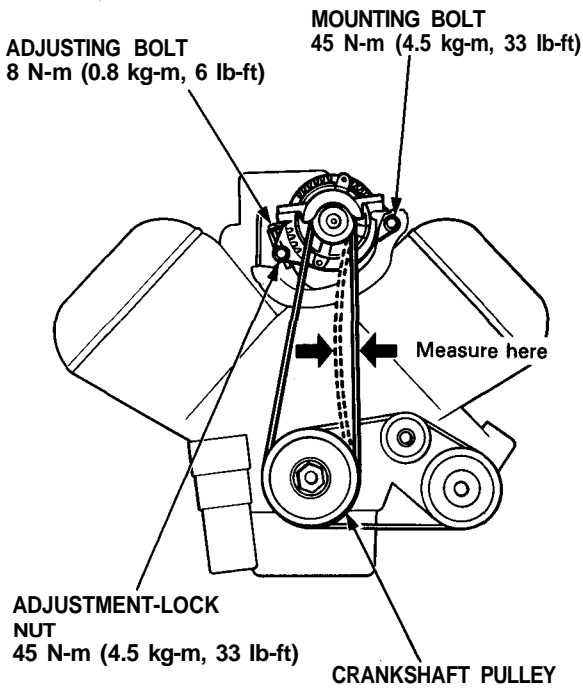

2. If belt deflection is incorrect, loosen the adjustment-lock nut and the mounting bolt.
3. Turn the adjusting bolt until belt deflection is correct, then retighten the nut and bolt.
4. Recheck the belt tension.

## Tension Gauge Method:

1. Attach the belt tension gauge to the belt and measure belt tension.

**Tension: 450-650 N (45-65 kg, 99-143 lbs)**

NOTE: On a brand-new belt, the tension should be 900-1100 N (90-110 kg, 198-243 lbs) before the belt has had any running time on the engine.

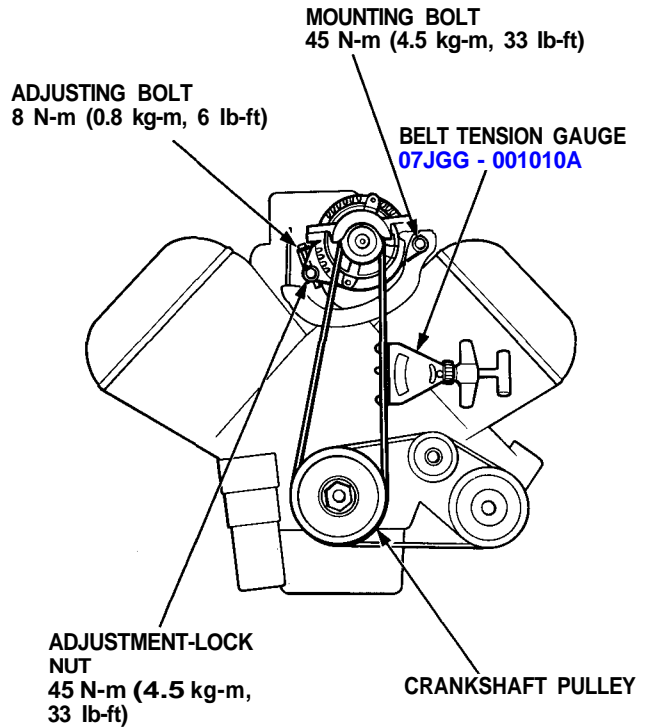

2. If belt tension is incorrect, loosen the adjustment-lock nut and the mounting bolt.
3. Turn the adjusting bolt until belt tension is correct, then retighten the nut and bolt.
4. Recheck the belt tension.