

Replacement

1. If the compressor still works, run the engine at idle for a few minutes with the A/C on, then shut the engine off and disconnect the negative cable from the battery.
2. Recover the refrigerant using a R-134a refrigerant Recovery/Recycling/Charging System. (see page 22-73).
3. Disconnect the compressor connector.

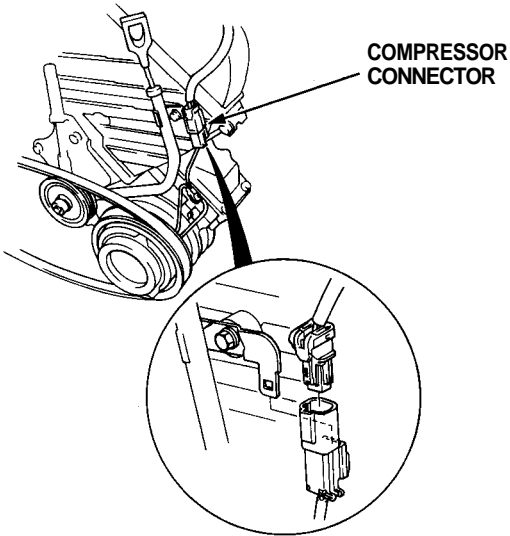

4. Raise the car on a hoist. Make sure it's properly supported (see section 1).
5. Remove the front beam (see section 5).
6. Disconnect the suction and discharge hoses from the compressor. Cap the open fittings immediately to keep moisture and dirt out of the system.

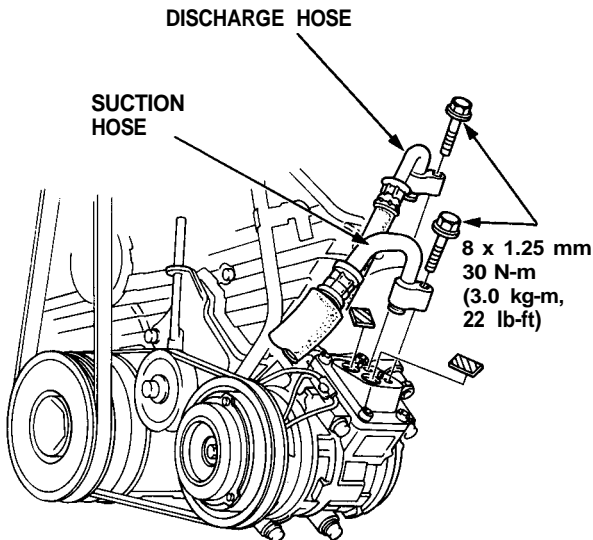

7. Loosen the idler pulley center nut and adjusting bolt, then remove the belt from compressor.

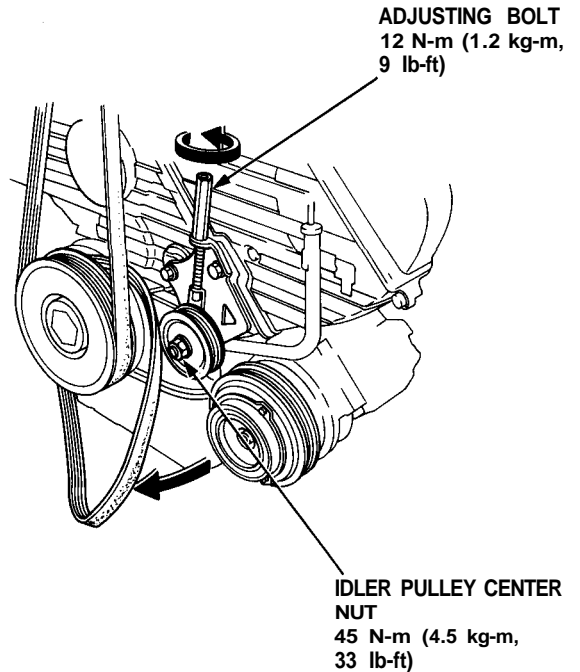

8. Remove the four mounting bolts and compressor.

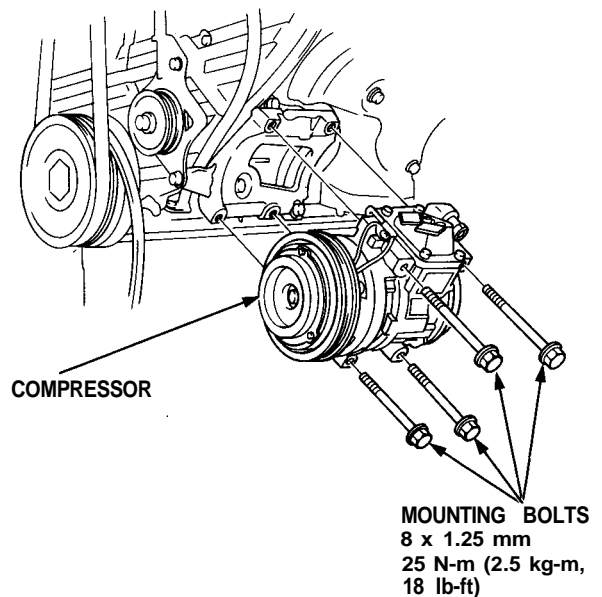

(cont'd)

Compressor

Replacement (cont'd)

9. If necessary, remove the one bolt from the idler pulley bracket, then remove the four mounting bolts and the compressor bracket.

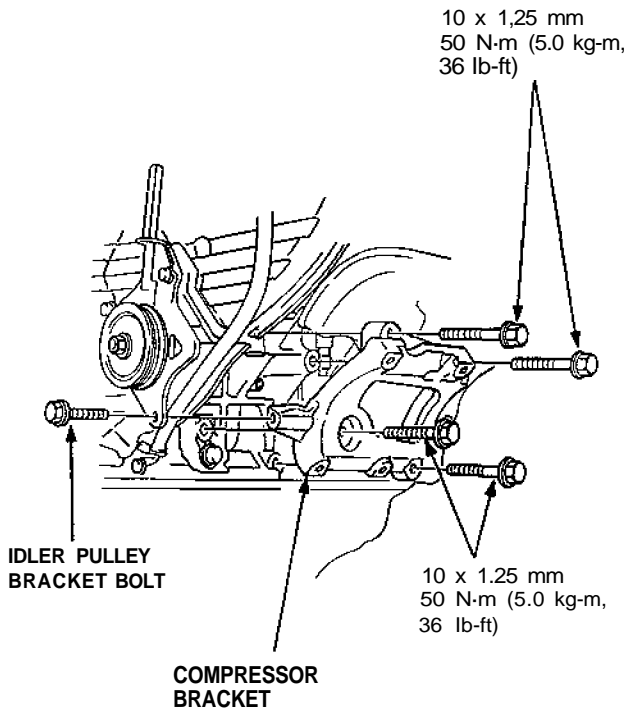

10. If necessary, remove the two other bolts in the idler pulley assembly.

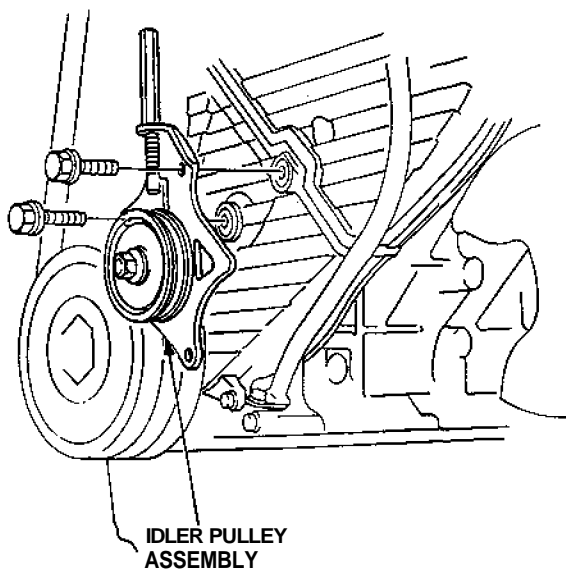

- Check the idler pulley bearing for play and drag. Replace it with a new one if it's noisy or has excessive play or drag.

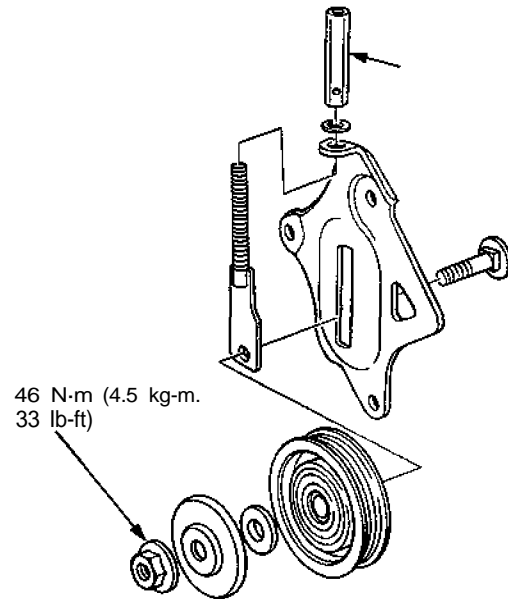

11. Install the compressor in the reverse order of removal; and:
- If you're installing a new compressor, drain all the refrigerant oil out of the old compressor and measure its volume. Subtract the volume of old Oil from 140 CC (4-2/3 floz); the result is the amount of oil you should drain from the new compressor (through the section fitting).
 - Replace O-rings with new ones at each fitting, and apply refrigerant oil to them.
NOTE: Be sure to use the right O-rings for R-134a to avoid leakage.
 - Use (ND-OIL 8) oil for R - 134a Nippondenso piston type compressors only.
 - Do not return the oil to the container once dispensed and never mix with other refrigerant oils to avoid contamination.
 - Immediately after using the oil, replace the cap on the container and seal it to avoid moisture absorption.
 - Do not spill the refrigerant oil on the car; it may damage the paint; if the refrigerant oil contacts the paint, wash it off immediately.
12. Adjust the compressor belt (see page 22-88). After adjusting the belt, tighten the idler pulley center nut. Then tighten the adjusting bolt securely,
13. Charge the system (see page 22-91).
14. Test system performance (see page 22-70).