

Heater-Evaporator Unit

Replacement

SRS components are located in this area. Review the SRS component locations, precautions, and procedures in the SRS [section \(24\)](#) before performing repairs or service.

1. Remove the blower unit (see page [22-67 \('93-'96\), 63\('91-'92\)](#)).
2. When the engine is cool, drain the engine coolant from the radiator (see [section 10](#)).

⚠ WARNING Do not remove the radiator cap when the engine is hot; the engine coolant is under pressure and could severely scald you.

CAUTION: Engine coolant will damage paint. Quickly rinse any spilled engine coolant off painted surfaces.

3. Disconnect the heater valve cable from the heater valve.
4. Disconnect the heater hoses. Engine coolant will run out when the hoses are disconnected, drain it into a clean drip pan.

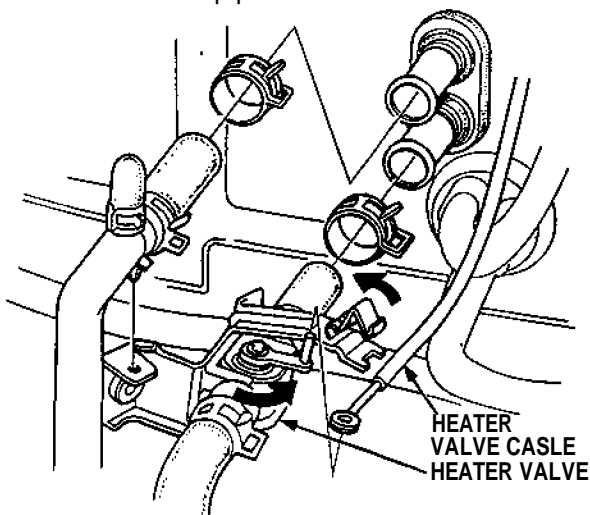

5. Recover the refrigerant from the A/C system with a R-134a refrigerant Recovery/Recycling/Charging System. (see page [22-73](#)).
6. Disconnect the receiver line and the suction line from the evaporator. Cap the open fittings immediately to keep moisture out of the system.

RECEIVER LINE
New parts (R-134a)

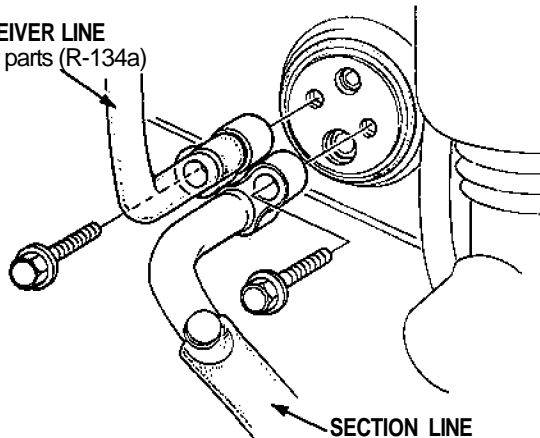

7. Remove the dashboard (see [section 20](#)).
8. Remove the heater duct.
9. Remove the four mounting bolts, disconnect the connectors from the control units and the evaporator temperature sensor connector from the control unit bracket, then remove the control unit bracket.

*: CORROSION RESISTANT BOLT

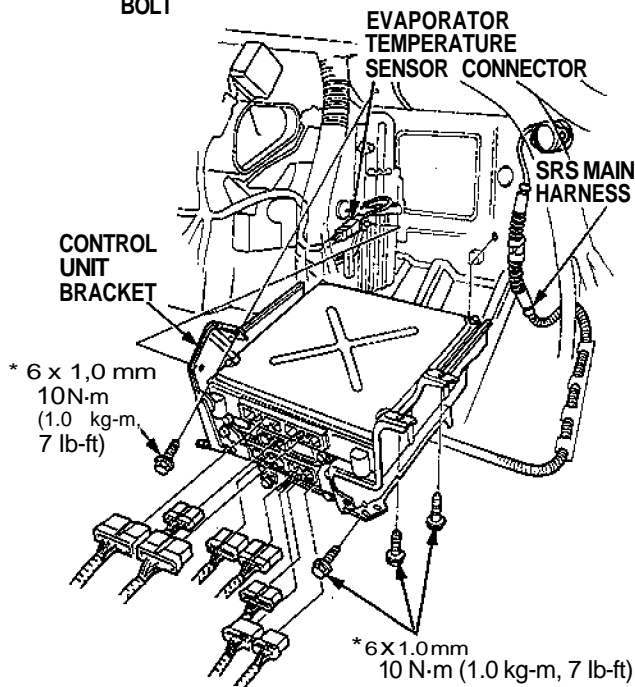

10. Remove the woofer enclosure (see [section 23](#)).



11. Disconnect the connectors from all the control motors and sensors attached to the heater-evaporator unit.
12. Remove the two mounting bolts and two nuts, then remove the heater-evaporator unit through the passenger door.

☆: CORROSION RESISTANT
BOLT

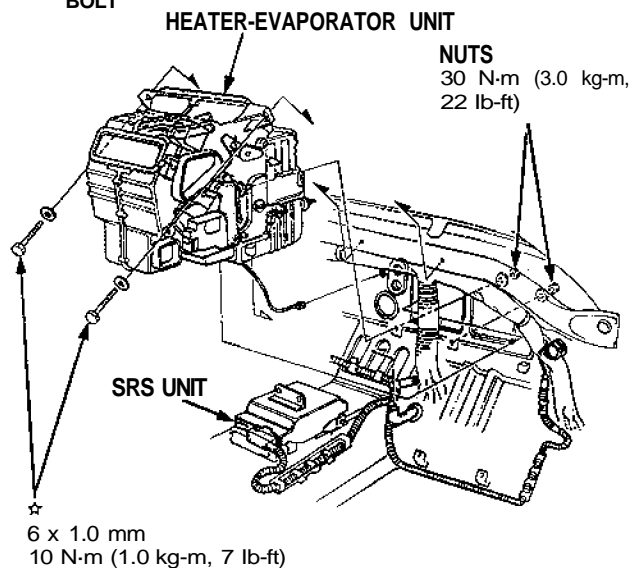

13. Install the heater-evaporator unit in the reverse order of removal, and:
 - If you're installing a new evaporator, add refrigerant oil (ND-OIL 8) see page 22-69 .
 - Replace 0-rings with new ones at each fitting, and apply refrigerant oil to them.
NOTE: Be sure to use the right 0-rings for R-134a to avoid leakage.
14. Fill the radiator and reservoir tank with the proper engine coolant mixture. Bleed the air from the cooling system (see section 10).

CAUTION: Follow the sequence described in the air bleed procedure. If you don't, you may leave air in the system which could damage the engine.

15. If necessary, adjust the heater valve cable:
 - Set the air mix control motor at COOL position (see page 22-57) .
 - Connect the end of the heater valve cable to the heater valve arm.
 - Gently slide the cable outer housing back from the end enough to take up any slack in the cable, but not enough to make the other end move the arm on the air mix control motor. Then snap the clamp down over the cable housing.

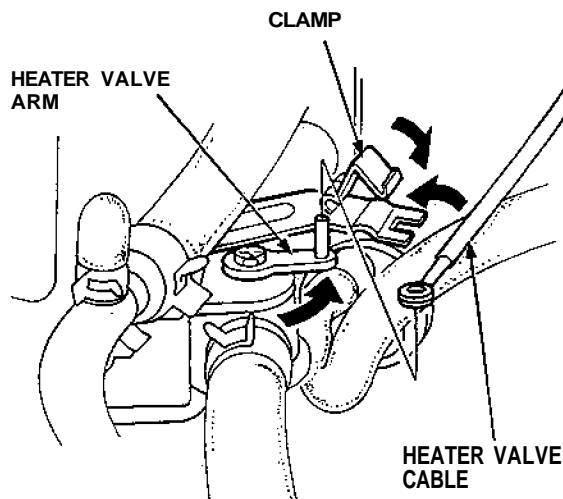

16. Turn the blower on, and make sure that there is no air leakage.
17. Charge the system (see page 22-91), and test performance (see page 22-70).