

# Heater Core Temperature Sensor

## Removal

Disconnect the connector, remove the clamp and the heater core temperature sensor.

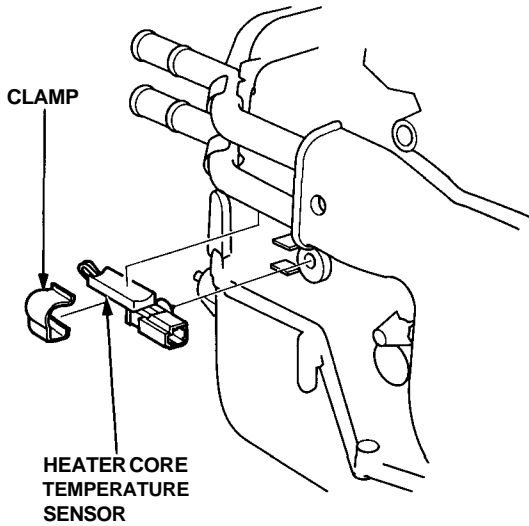

## Test

Compare the resistance reading between the terminals of the heater core temperature sensor with specifications shown in the following graph: It should be within specification.

NOTE: Dip the sensor in ice water, and measure the resistance. Then pour hot water on the sensor, and check for change in resistance.

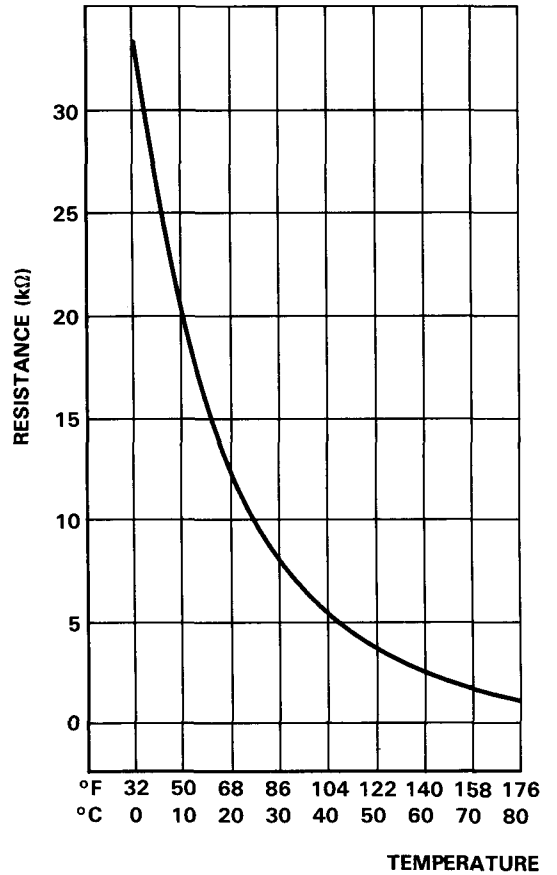

**CAUTION:** The sensor uses a thermistor which can be damaged if high current is applied to it during testing. Therefore, use a circuit tester that puts out a measuring current of 1 mA or less.

