

Recirculation Control Motor

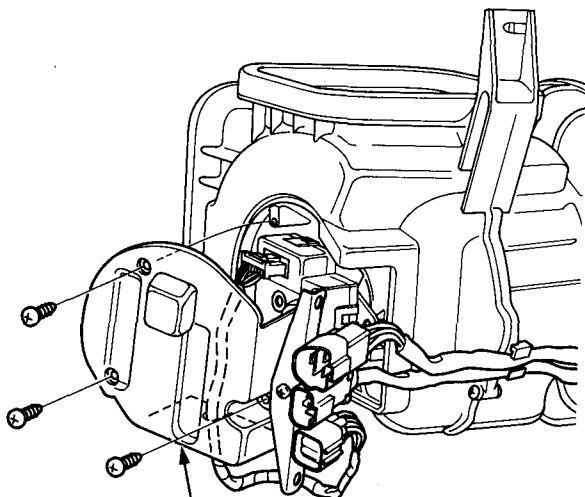

Replacement

1. Remove the blower unit (see page 22-67)
2. Remove the three screws and the recirculation control motor cover from the blower unit.



RECIRCULATION CONTROL MOTOR COVER

3. Remove the three screws and the recirculation control motor.

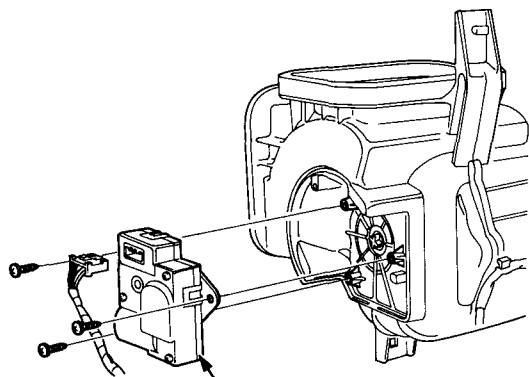

RECIRCULATION CONTROL MOTOR

4. Install the recirculation control motor in the reverse order of removal. Then apply battery voltage, and watch the door movement.

- Make sure that the recirculation door moves smoothly without binding.
- Make sure the motor doesn't pull the door too far.

Test

1. Connect battery power to the No. 1 terminal of the recirculation control motor, then connect ground to the No. 2 terminal; the recirculation control motor should run, and stop at REC. If it doesn't, reverse the connections; the recirculation control motor should run, and stop at FRE.

NOTE: If the recirculation control motor does not run, remove it, and check the recirculation control linkage and door for smooth movement. If the recirculation control linkage and door move smoothly, replace the recirculation control motor.

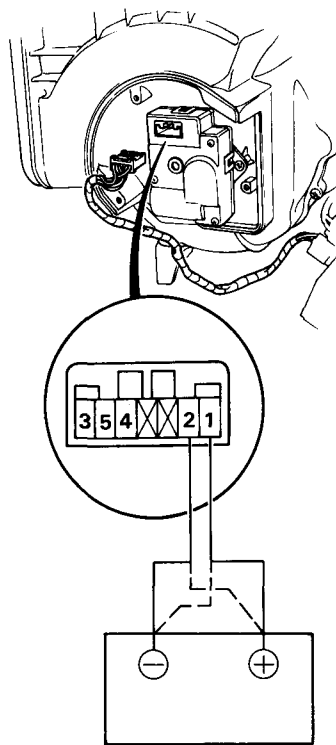

2. Check for continuity between the terminals of the recirculation control motor according to the table.

Terminal Position	3	4	5
	○	○	
	○		○