

Roof



Roof Side Lock Unit Replacement

CAUTION: To prevent damage, place the roof on an appropriate pad.

1. Remove the roof.
2. Remove:
 - Roof front trim (see page 20-82)
 - Roof side trim (see page 20-82)
 - Roof side seal (see page 20-84)
 - Roof side retainer (see page 20-84)
3. Install the roof side lock handle.
4. Turn the roof side lock handle to the locked position.
5. Remove the nuts and rear roof holder, then remove the roof side lock unit. Remove the roof side lock handle.

NOTE: Take care not to bend the lock pins.

●: Nut locations, 6



6 x 1.0 mm
11 N-m (1.1 kg-m,
8 lb-ft)

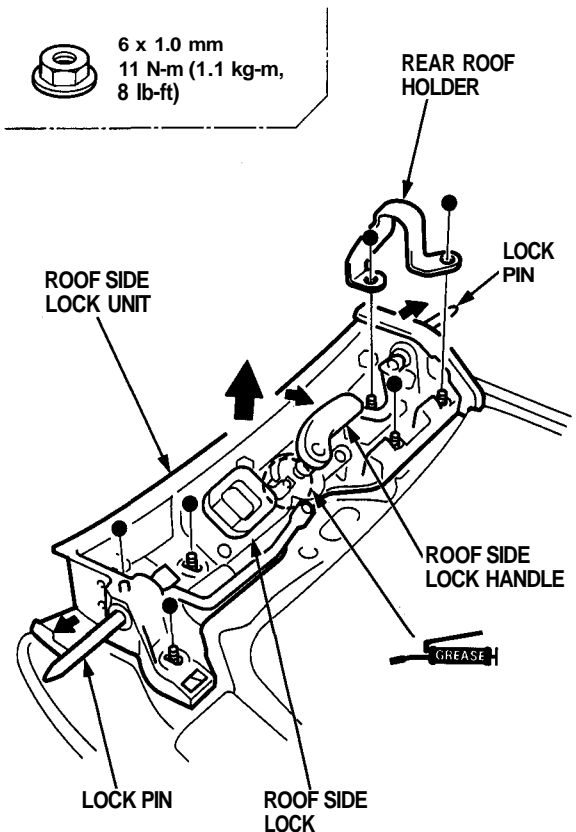

(cont'd)

Roof

Roof Side Lock Unit Replacement (cont'd)

6. If necessary, remove the roof side hook.

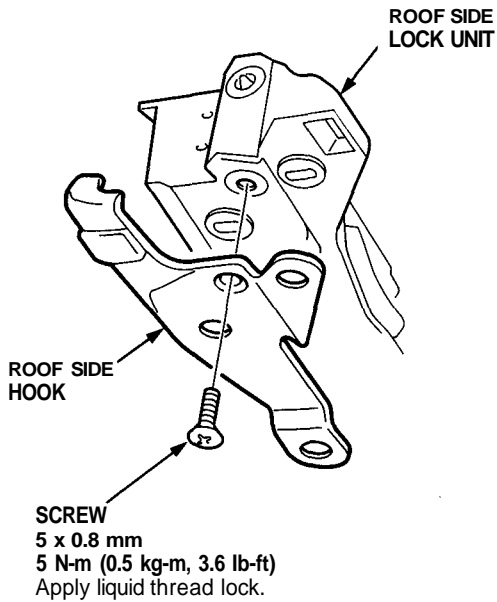

7. Installation is the reverse of the removal procedure.

NOTE:

- Grease the location indicated by the arrow and the lock pins.
- Make sure the roof side lock works smoothly.
- Install the roof side retainer and roof side seal properly as described on page [20-85](#).
- Before installing the roof trim, install the roof on the body, then check that the seals fit flush (see page [20-107](#)).
If necessary, align the roof side seals by adjusting the roof side lock unit (see page [20-106](#)).
- Check that the door glass contacts the seals evenly (see page [20-109](#)).
- Check for water leaks (see page [20-110](#)).