



# Seat Belts

## Replacement

SRS wire harnesses are routed near the retractor.

**WARNING** All SRS wire harnesses and connectors are colored yellow. Do not use electrical test equipment on these circuits.

**CAUTION:**

- Be careful) not to damage the SRS wire harnesses when servicing the retractor.
- Remove the short connector (RED) from the its holder and disconnect the SRS wire harness connector, then connect the short connector (RED) to the tensioner connector.

NOTE: To prevent dust, wrap the SRS wire harness connector with a protective cover.

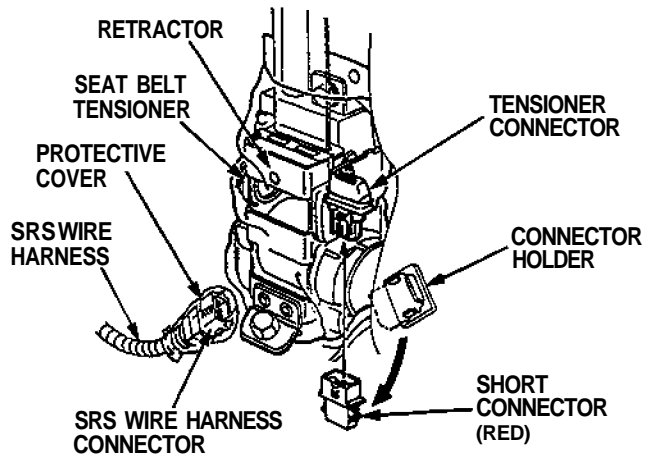

**CAUTION:** Check the seat belts for damage, and replace them if necessary. Be careful not to damage them during removal and installation.

1. Remove:
  - Seat (see page 20-39('93-'96), 38)
  - Center pillar trim panel (see page 20-38)
2. Remove the three anchor bolts, retractor bolt and retractor mounting bolt, then remove the seat belt and seat belt buckle.

**CAUTION:** When removing the retractor, do not touch the seat belt tensioner.

NOTE: When removing the anchor bolts and retractor bolt, use a 17 mm socket or box-end wrench.

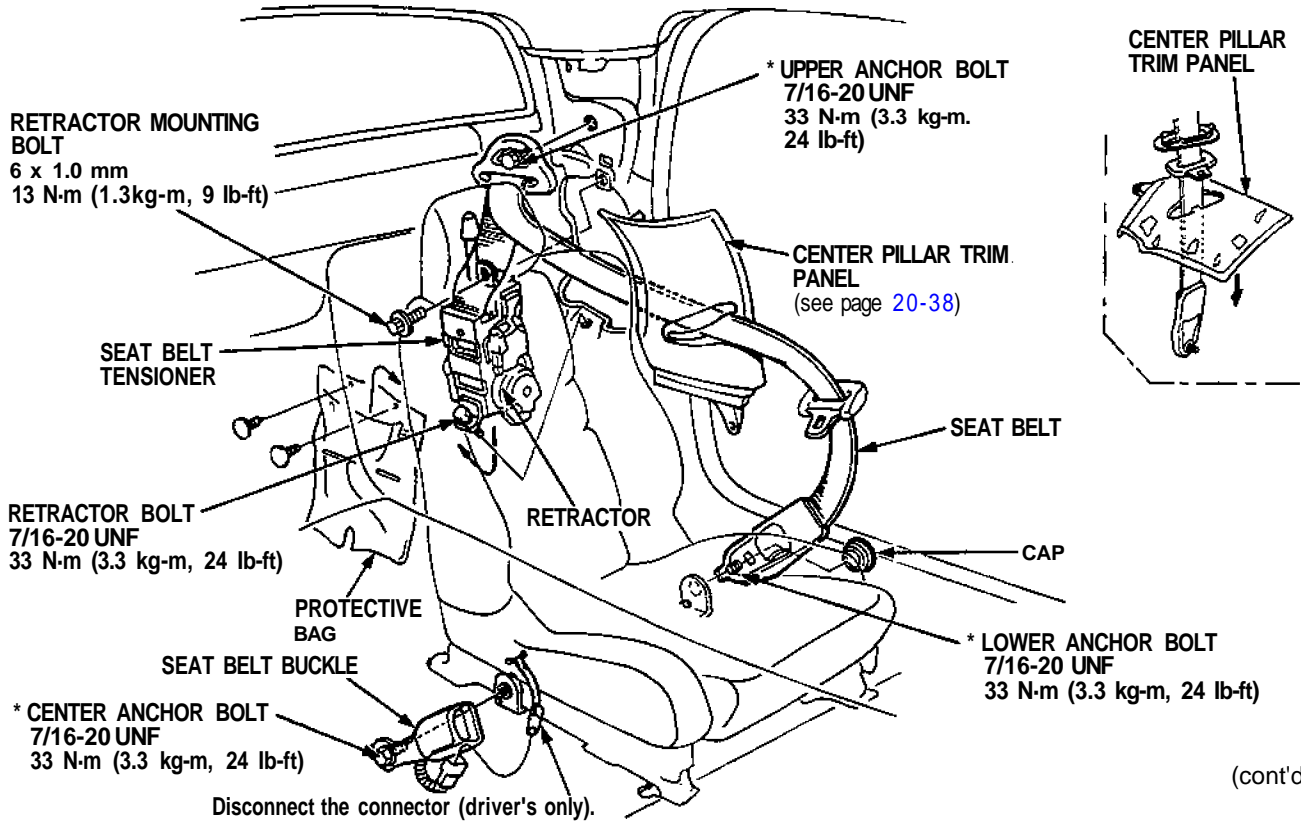

(cont'd)

# Seat Belts

## Replacement(cont'd)

Anchor bolt construction:

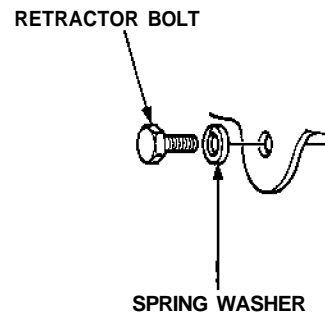
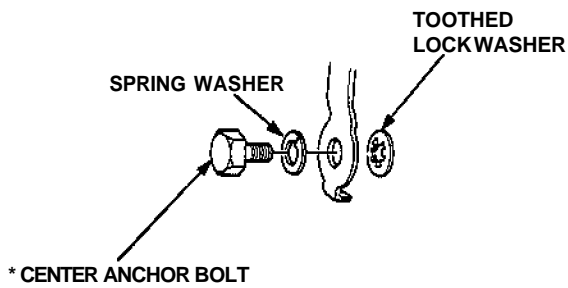
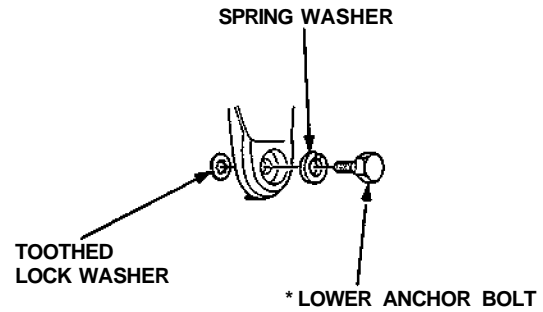
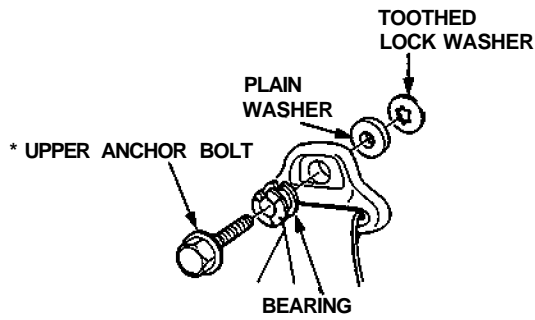

3. Check that the retractor locking mechanism functions as described on page [20-45\('93-'96\)](#) ('91-'92).
4. Installation is the reverse of the removal procedure.

**NOTE:**

- Make sure you assemble the washers on the anchor bolts as shown.
- Before attaching the center pillar trim panel, make sure there are no twists or kinks in the seat belts.
- On reassembly, replace the anchor bolts (\*) and use liquid thread lock.