

# Rear Hatch Glass Molding

## Replacement

**CAUTION:**

- Wear gloves to replace the molding.
- Do not damage the glass and defroster grid lines.

1. Remove the rear hatch assembly (see page 20-64).
2. Place the rear hatch assembly on its surface as shown.

**CAUTION:** Avoid setting the glass on its edges; small chips may later develop into cracks.

3. With a helper holding the rear hatch assembly, carefully cut off the molding.

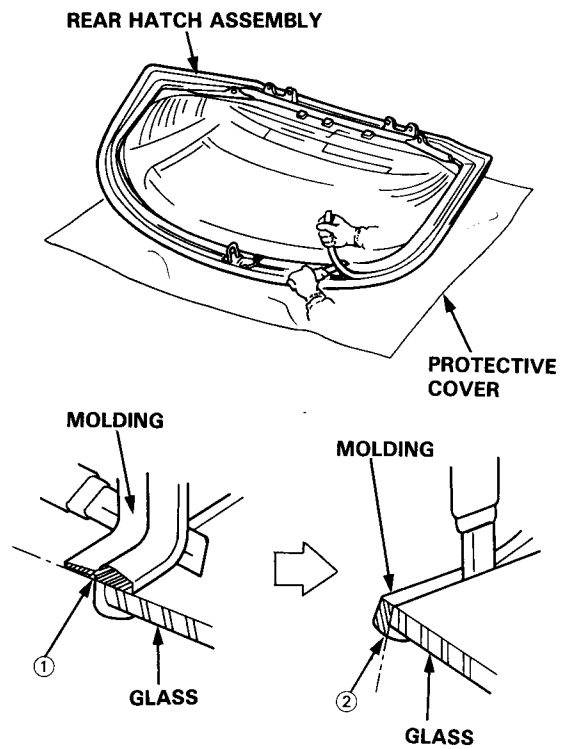

4. Turn the glass over, then cut the outer side rubber portion **③** of the molding.

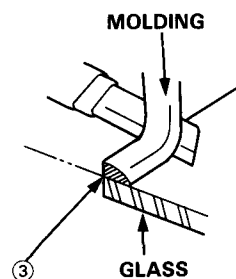



- Scrape all traces of the old molding from the chamfered edges of the glass.

NOTE: Be sure to scrape all traces of the old molding thoroughly.

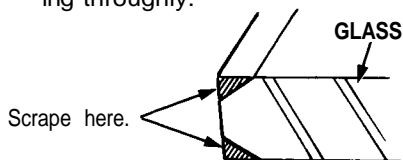

- Clean the glass surface with alcohol where the new molding is to be installed.

NOTE: Make sure the surface is kept free of water, oil and grease.

- With a brush, apply a light coat of glass primer around the edge of the glass.

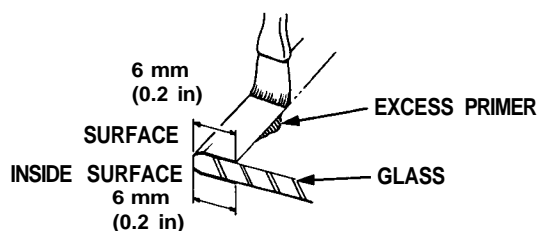

NOTE: Scrape off excess glass primer with a putty knife after installing the new molding.

- Degrease the inner surfaces of the new molding thoroughly, then apply a light coat of glass primer to the surfaces.

NOTE:

- Apply glass primer around the entire groove of the new molding.
- Do not apply glass primer to the outer surface.

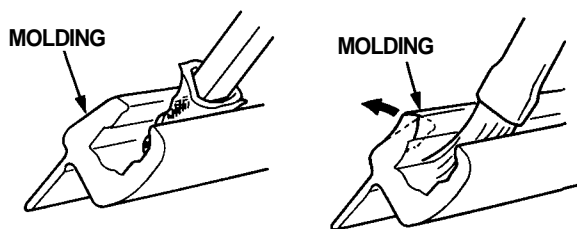

- Run a bead of adhesive in the groove of the molding.

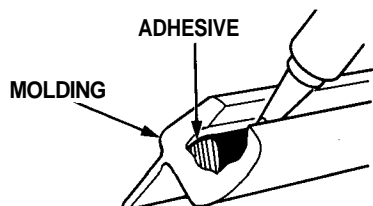

- Press the molding into position around the entire edge of the glass.

NOTE: Check that the molding is not wrinkled or lifted away at the corners.

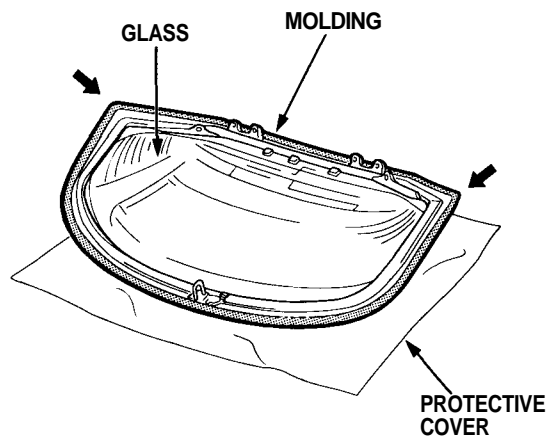

- Scrape or wipe the excess adhesive off with a putty knife or towel.

NOTE: Use a soft shop towel dampened with alcohol to remove adhesive from a painted surface or glass.

(Glass Surface)

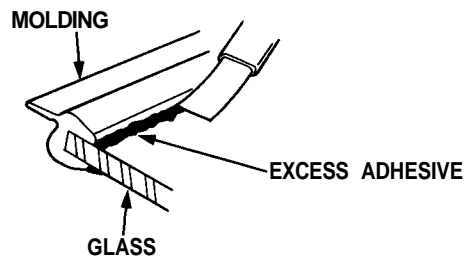

Inside:

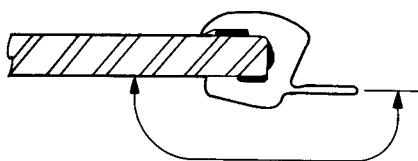

Outside:

