



Windshield

Removal

CAUTION:

- Wear gloves to remove and install the windshield.
- Use covers to avoid damaging any surfaces.

1. To remove the windshield, first remove the:
 - Seats (see page 20-39('93-'96)('91-'92))
 - Rearview mirror (see page 20-46('93-'96)('91-'92))
 - Sunvisors (see page 20-38('93-'96),37('91-'92))
 - Front pillar retainer (see page 20-21('93-'96),20('91-'92))
 - Front wiper and air scoop (see section 23)
 - Front pillar trim and headliner (see page 20-38('93-'96),37('91-'92))
2. Peel off the upper molding.
3. Apply protective tape along the edge of the dashboard and body next to the windshield as shown.

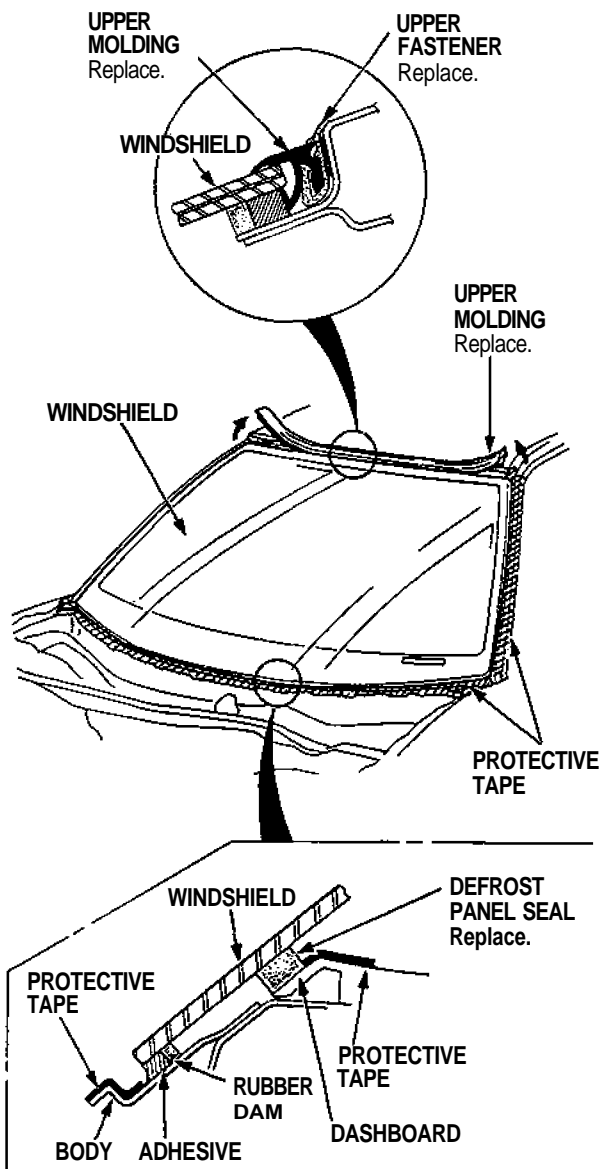

4. Using an awl, make a hole through the adhesive from inside the car. Push piano wire through the hole, and wrap each end around a piece of wood.

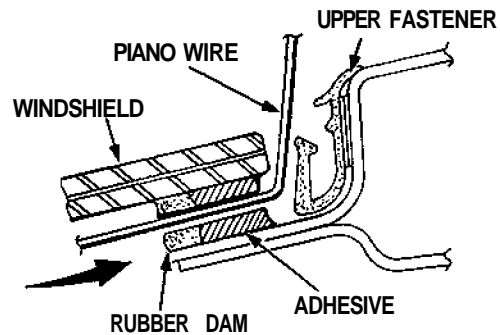

5. With a helper on the outside, pull the piano wire back and forth in a sawing motion and carefully cut through the adhesive around the entire windshield.

CAUTION:

- Hold the piano wire as close to the windshield as possible to prevent damage to the body and dashboard.
- Take care not to damage the vehicle identification number plate.

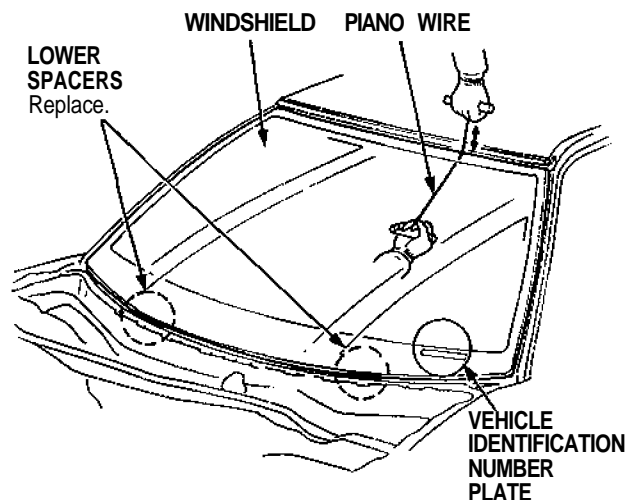

6. Cut the lower spacers and upper fastener away from the body with a knife; they are cemented in place.

NOTE: Replace the lower spacers with new ones whenever the windshield has been removed.