

ABS Control Unit

Replacement

SRS components are located in this area. Review the SRS component locations, precautions, and procedures in the SRS [section 24](#) before performing repairs or service.

1. Remove the dashboard lower cover and glove box, and disconnect the light connector.

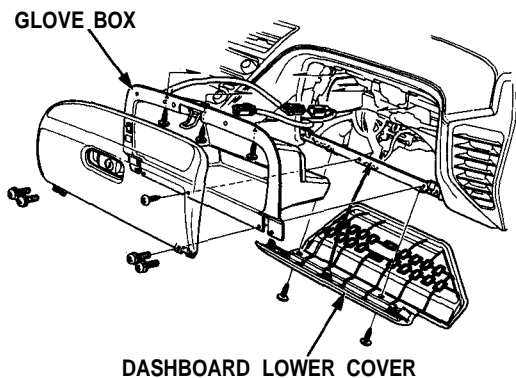

2. Move the heater duct to the right and remove it.

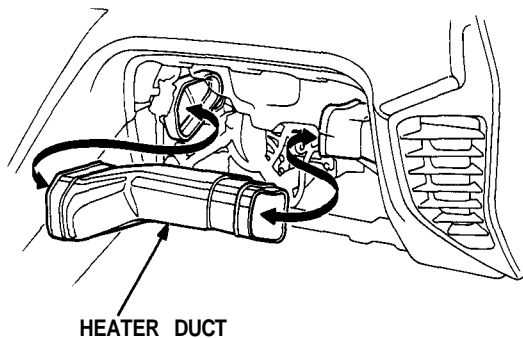

3. Disconnect the connectors from the ABS control unit by removing the wire harness band.

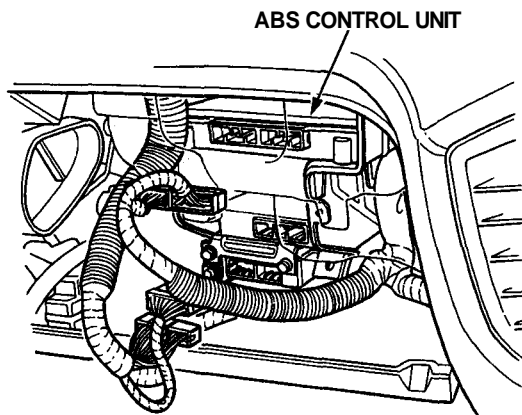

4. Remove the four control unit attaching bolts, then remove the bracket with the control unit.
5. Remove the ABS control unit from the bracket.

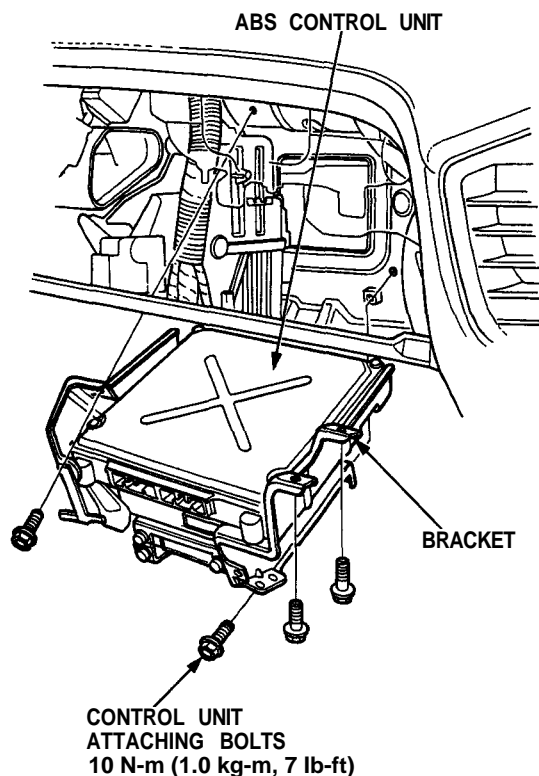

6. Installation is the reverse of removal procedure.

NOTE: After installation, start the engine and make sure that the ABS indicator light goes off.