

Pushrod Clearance Adjustment

NOTE: Master cylinder pushrod-to-piston clearance must be checked and adjustments made, if necessary, before installing master cylinder.

1. Set the special tool on the master cylinder body; push in the center shaft until the top of it contacts with the end of the secondary piston by turning the adjusting nut.

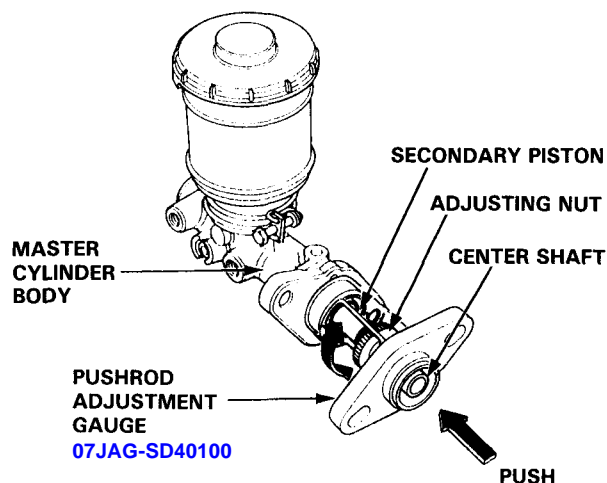

2. Without disturbing the center shaft's position, install the special tool upside down on the brake booster.
3. Install the master cylinder nuts and tighten to the specified torque.
4. Connect the brake booster in-line with a vacuum gauge 0-760 mm Hg (0-30 in Hg) to the booster's engine vacuum supply, and maintain an engine speed that will deliver 500 mm Hg (20 in Hg) vacuum.
5. With a feeler gauge, measure the clearance between the gauge body and the adjusting nut as shown.

Clearance: 0–0.4 mm (0–0.02 in)

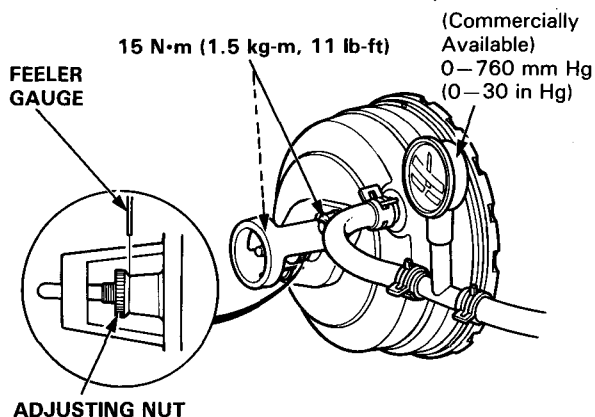

NOTE: If the clearance between the gauge body and adjusting nut is 0.4 mm (0.02 in), the pushrod-to-piston clearance is 0 mm. However, if the clearance between the gauge body and adjusting nut is 0 mm, the pushrod-to-piston clearance is 0.4 mm (0.02 in) or more. Therefore, it must be adjusted and rechecked.

6. If clearance is incorrect, loosen the star locknut and turn the adjuster in or out to adjust.

NOTE:

- Adjust the clearance while the specified vacuum is applied to the brake booster.
- Hold the clevis while adjusting.

7. Tighten the star locknut securely.
8. Remove the special tool, and install a new master cylinder rod seal in the brake booster.

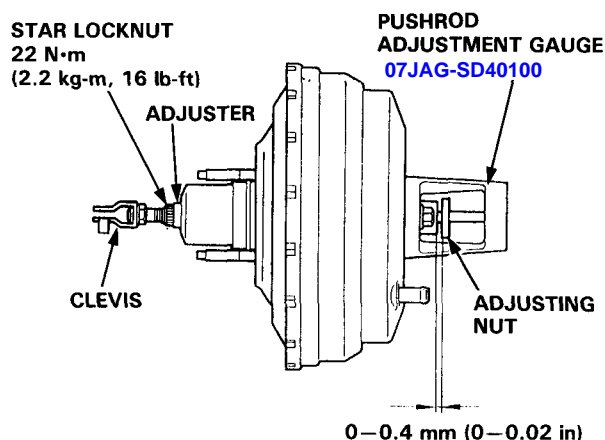

9. Adjust the pushrod length as shown if the booster is removed.

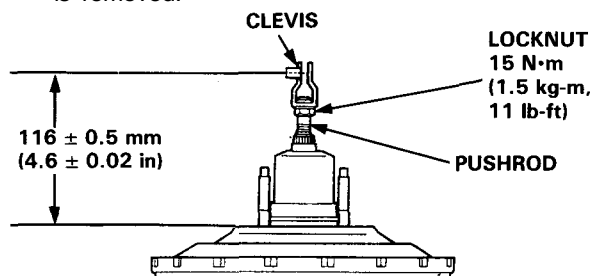

10. Install the master cylinder (see page 19-12).
11. After installation, perform the following inspections and adjust if necessary.
 - Brake pedal height (see page 19-4).
 - Brake pedal free play (see page 19-4).