

Front Caliper

Disassembly

⚠ WARNING

- Never use an air hose or dry brush to clean brake assemblies.
- Use an OSHA-approved vacuum cleaner to avoid breathing brake dust.

CAUTION:

- Do not spill brake fluid on the car; it may damage the paint; if brake fluid does contact the paint, wash it off immediately with water.
- To prevent spills, cover the hose joints with rags or shop towels.
- Clean all parts in brake fluid and air dry; blow out all passages with compressed air.

1. Remove the banjo bolt, and disconnect the brake hose from the caliper.
2. Remove the caliper mounting bolts, then remove the caliper.

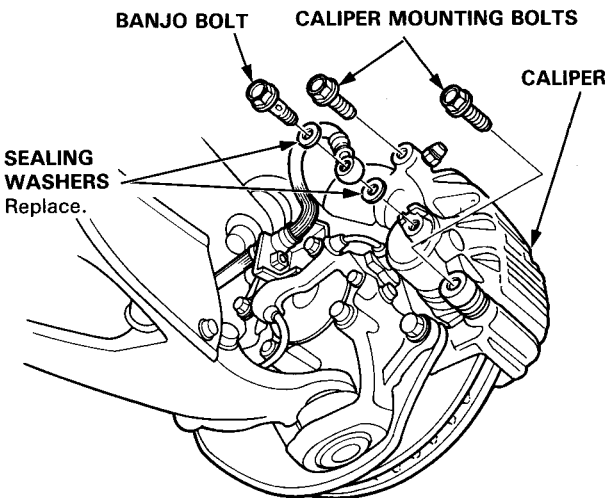

3. Remove the pad spring from the caliper body.

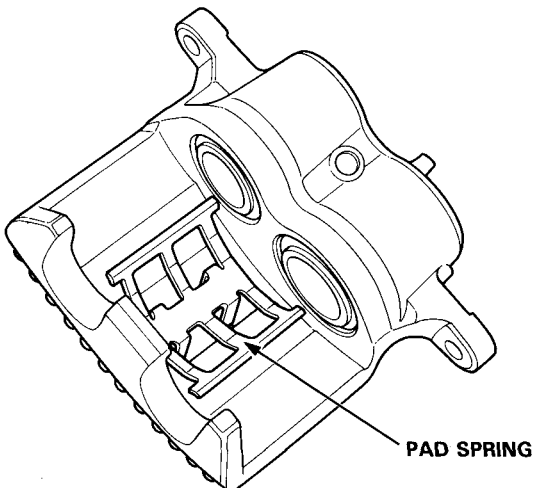

4. If necessary, apply compressed air to the caliper fluid inlet to get the pistons out. Place a shop rag or wooden block as shown to cushion the pistons when there are expelled. Use low pressure air in short spurts.

⚠ WARNING

- Do not place your fingers in front of the piston.
- Do not use high air pressure; use an OSHA-approved 30 PSI nozzle.

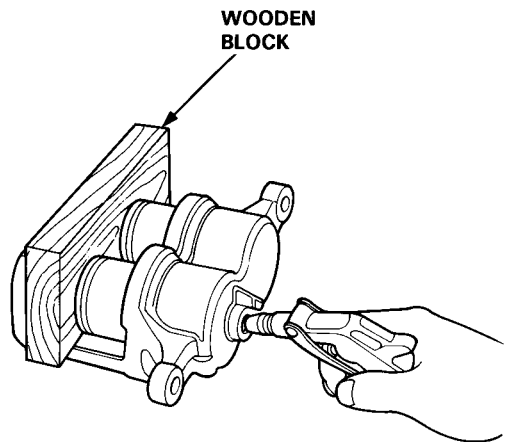

5. Remove the piston boots and piston seals.

CAUTION: Take care not to damage the cylinders.

