

# Rear Damper

## Removal

1. Remove the rear wheels.
2. Remove the lower rear hatch glass trim.

REAR HATCH GLASS TRIM

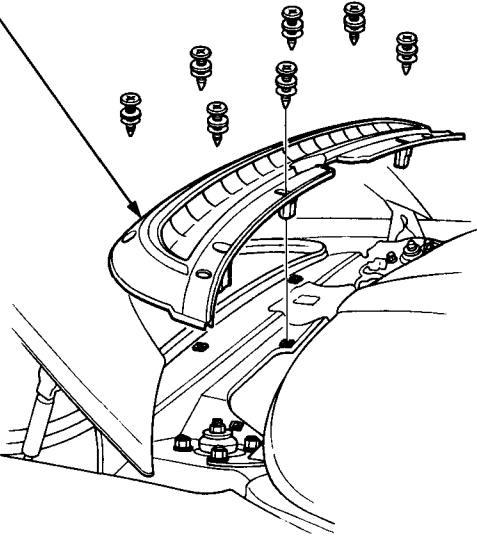

3. For NSX-T, remove the engine cover support rod from the strut brace, then position the end of the rod on the window lock mechanism to support the engine cover.

NOTE: To prevent damage to the window lock mechanism, place a shop towel over the mechanism.

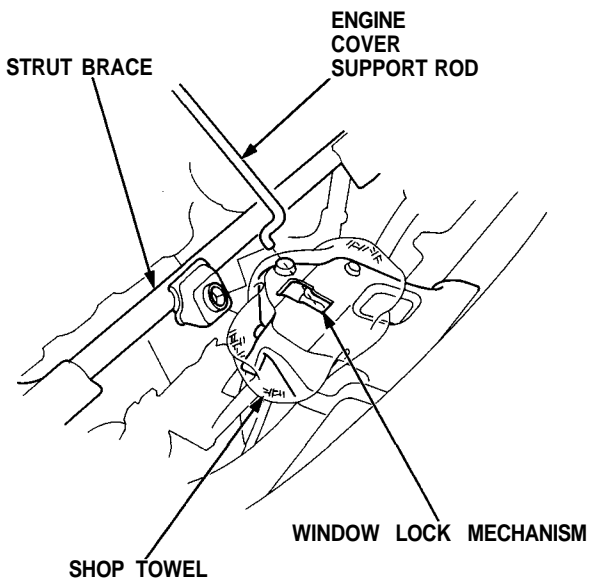

4. Remove the three self-locking nuts.
5. Remove the rear strut brace.

STRUT BRACE

☆ SELF-LOCKING NUT  
10 x 1.25 mm  
Replace.

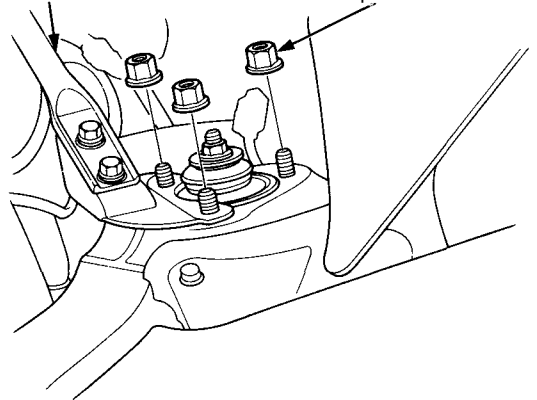

☆: Corrosion resistant bolt/nut

6. Hold the damper lower mount of stabilizer link with a wrench, then remove the damper mounting nut.
7. Hold the ball pin of the stabilizer link with a hex wrench, then loosen the self-locking nut.

☆ DAMPER MOUNTING NUT  
12 x 1.25 mm  
Replace.  
95 N-m (9.5 kg-m, 69 lb-ft)

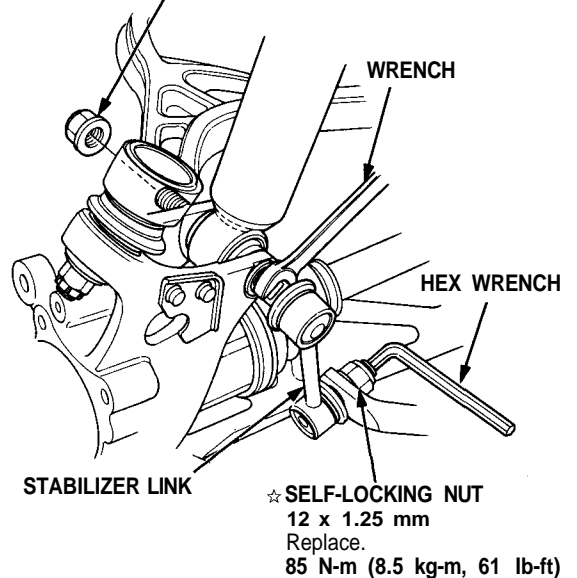

☆ SELF-LOCKING NUT  
12 x 1.25 mm  
Replace.  
85 N-m (8.5 kg-m, 61 lb-ft)

☆: Corrosion resistant bolt/nut



8. Remove the self-locking nut, then remove the stabilizer link from the stabilizer bar and knuckle.

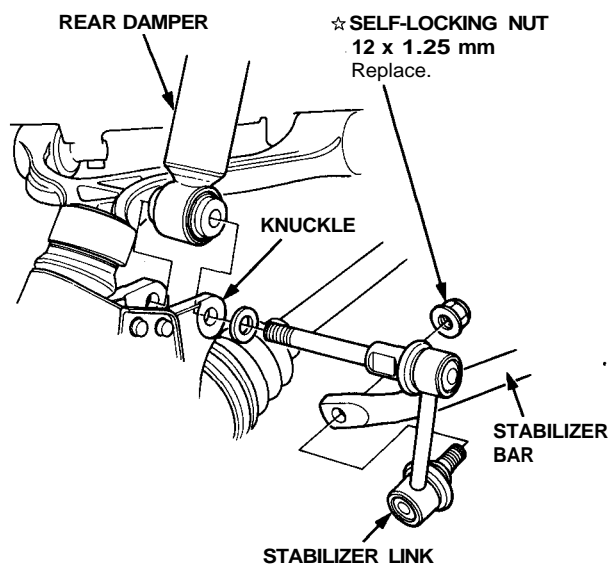

☆: Corrosion resistant bolt/nut