



Steering Column

Removal

SRS components are located in this area. Review the SRS component locations, precautions, and procedures in the SRS [section 24](#) before performing repairs or service.

1. Disconnect both the negative cable and positive cable from the battery.
2. Remove the airbag assembly and steering wheel from the column (see page [17-45](#)).
3. Remove the dashboard lower panel, dashboard lower pad, and dashboard brace.

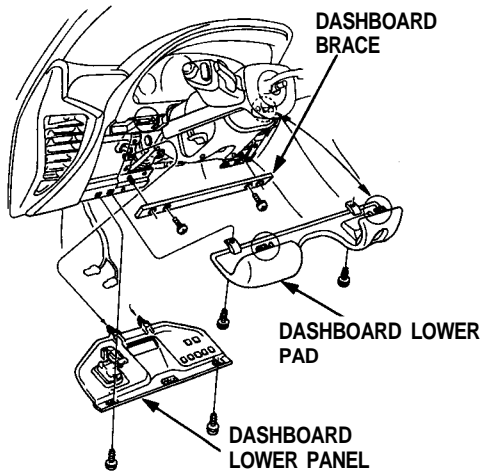

4. Disconnect the connector between the cable reel and the SRS main harness, then remove the connector holder.
5. Remove the column lower panel.

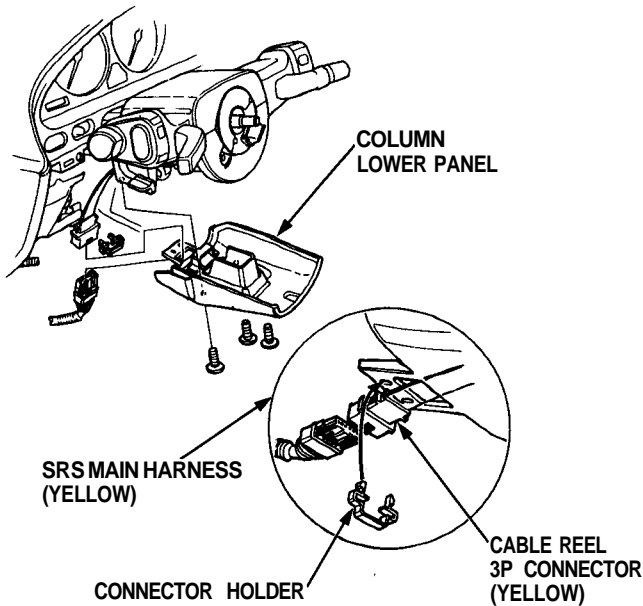

6. Remove the column covers.

NOTE: Be careful not to damage the column covers.

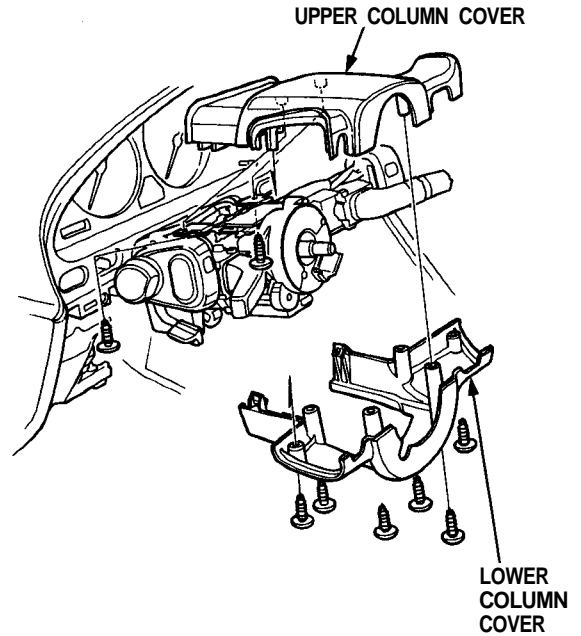

7. Disconnect the TCS sensor connector.

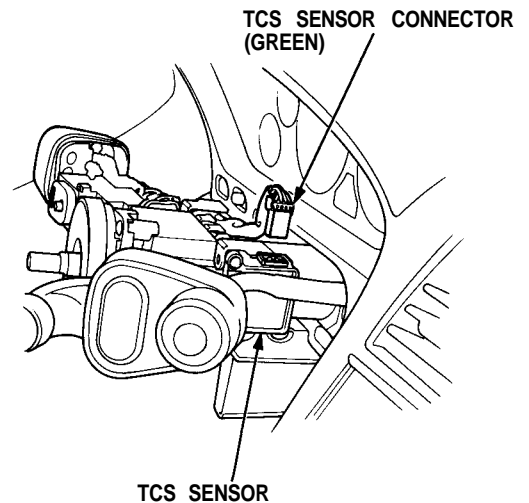

(cont'd)

Steering Column

Removal (cont'd)

8. Remove the combination switch assembly from the column shaft.

NOTE: The combination switch can be removed by disconnecting only the TCS sensor connector.

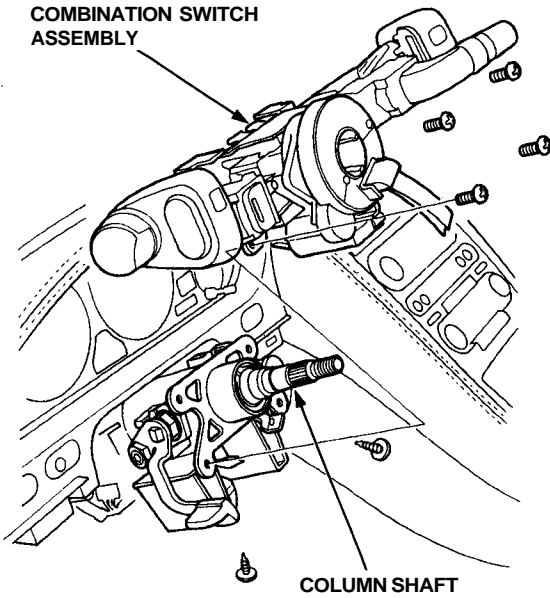

9. Remove the steering joint cover.

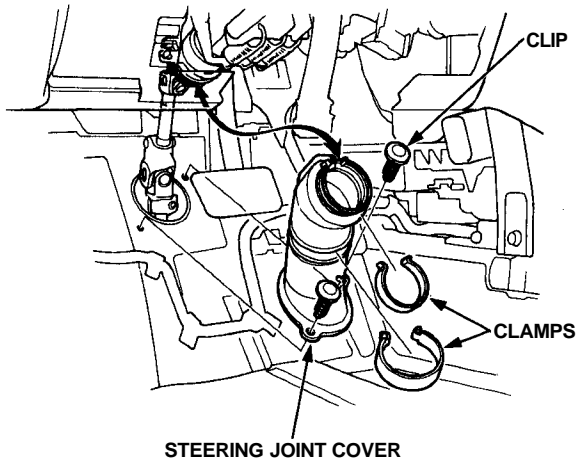

10. Remove the steering joint bolts and toothed lock washers from the steering joint.

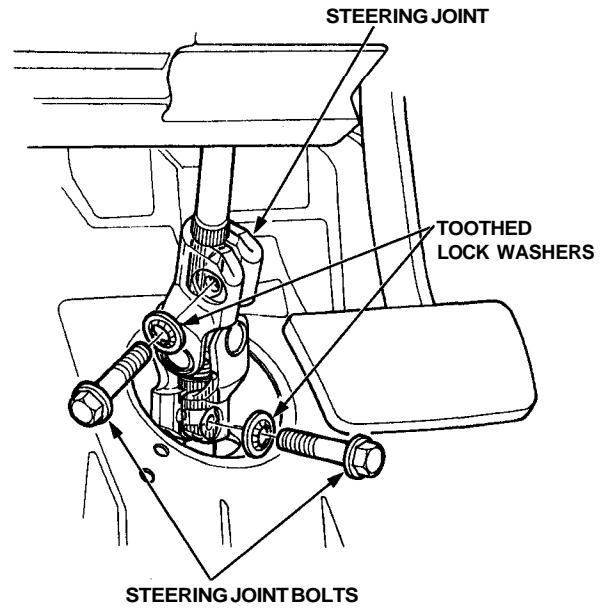

11. Disconnect the ignition switch connectors and remove the column holder, then remove the steering column assembly by removing the 8 mm bolts and flange nuts.

