

Driveshafts

Reassembly

Outboard joint side

NOTE: Wrap the splines with vinyl tape to prevent damage to the boot.

1. Install the outboard boot to the driveshaft, then remove the vinyl tape.

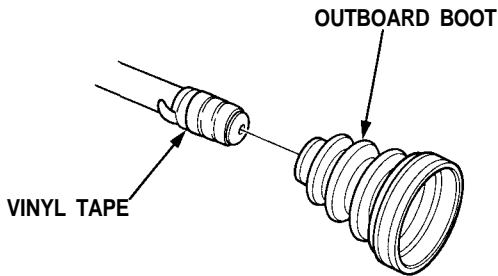

2. Install the set ring into the driveshaft groove.
3. Install the spider on the driveshaft by aligning the marks on the spider and end of the driveshaft.
4. Install the set ring into the driveshaft groove.

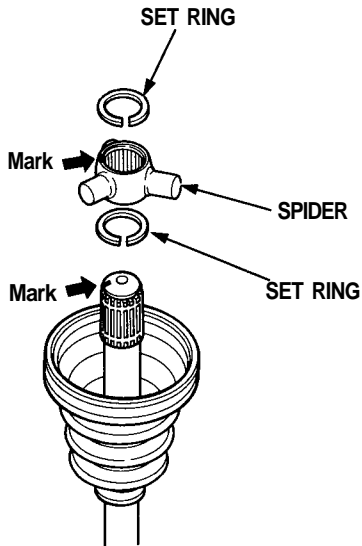

5. Fit the rollers to the spider with their high shoulders facing outward.

CAUTION:

- Reinstall the rollers in their original positions on the spider.
- Hold the driveshaft assembly pointed up to prevent the rollers from falling off.

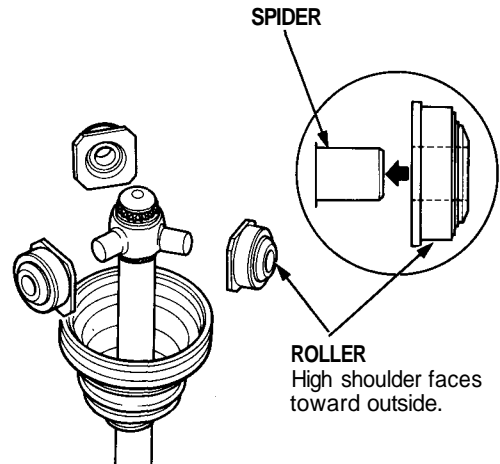

6. Pack the joint with joint grease included in the new joint boot set.

Grease Quantity: 170 - 180 g (6.0-6.3 oz)

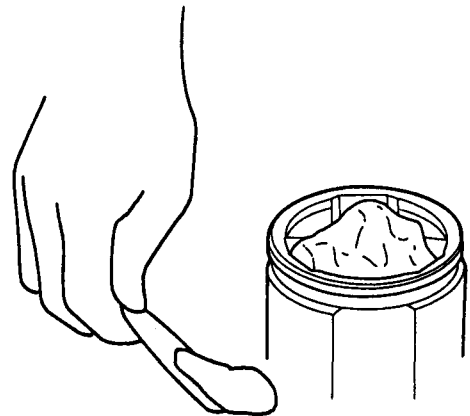



7. Install the spring and cap, then fit the outboard joint onto the driveshaft.

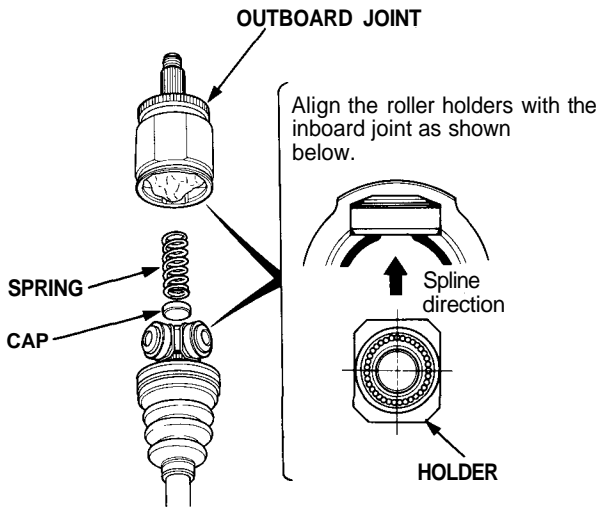

8. Fit the circlip into the outboard joint inner groove.

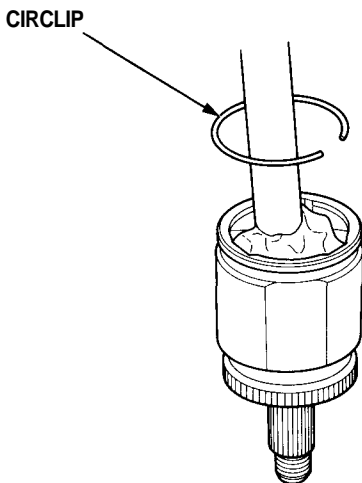

Inboard joint side

NOTE: Wrap the splines with vinyl tape to prevent damage to the boot.

9. Install the inboard boot to the driveshaft, then remove the vinyl tape.

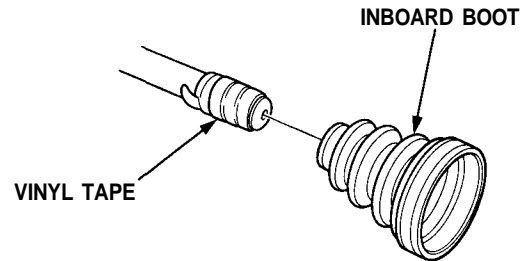

10. Install the set ring into the driveshaft groove.
11. Install the spider on the driveshaft by aligning the marks on the spider and end of the driveshaft.
12. Install the set ring into the driveshaft groove.

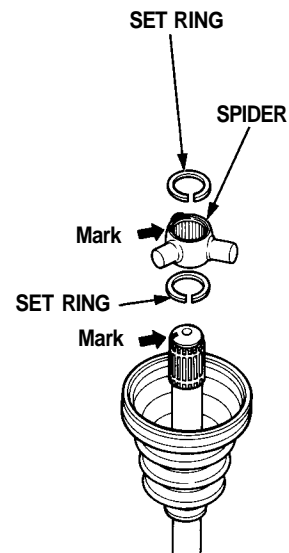

(cont'd)

Driveshafts

Reassembly (cont'd)

13. Fit the rollers to the spider with their high shoulders facing outward.

CAUTION:

- Reinstall the rollers in their original positions on the spider.
- Hold the driveshaft assembly with the rollers up to prevent them from falling off.

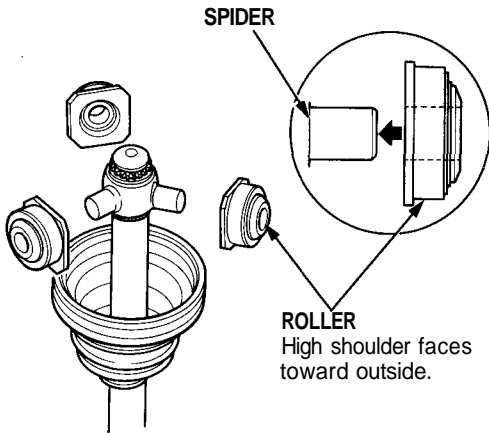

14. Pack the joint with joint grease included in the new joint boot set.

Grease Quantity: 120-130 g (4.2-4.6 oz)

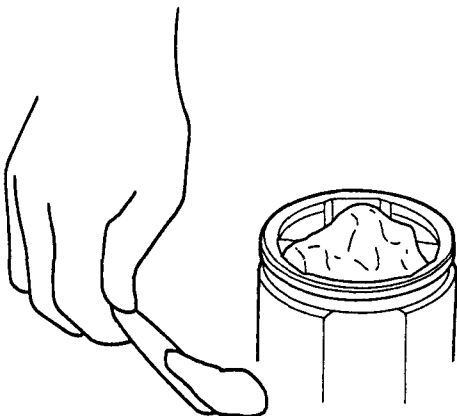

15. Fit the inboard joint onto the driveshaft.

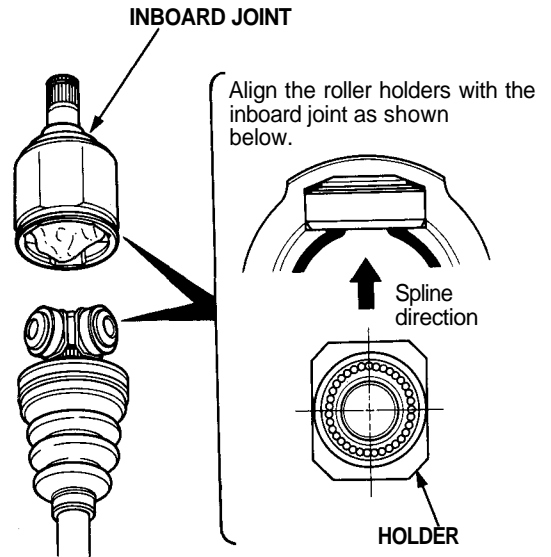

16. Adjust the length of the driveshafts to the figure below, then adjust the boots to halfway between full compression and extension.

NOTE: The ends of the boots seat in the grooves of the driveshaft and joint.

Left Driveshaft

M/T: 501.0-506.0 mm (19.72-19.92 in)

A/T: 507.0-512.0 mm (19.96-20.16 in)



Right Driveshaft

M/T and A/T: 542.0-547.0 mm (21.34-21.54 in)

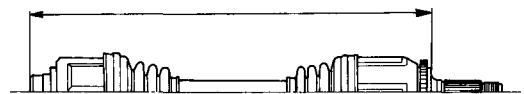



17. Install new boot bands on the boots, then bend both sets of locking tabs.
18. Lightly tap on the doubled-over portions to reduce their height.

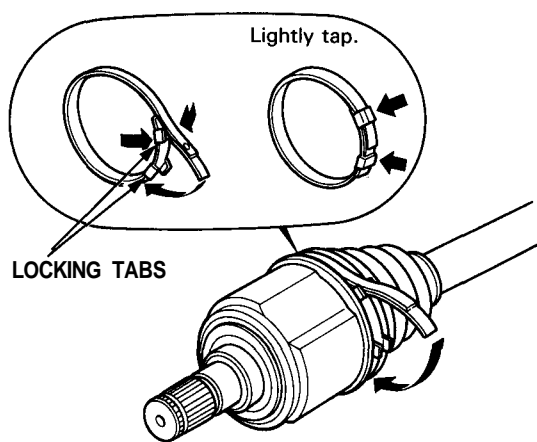

NOTE: Install the outboard joint in the knuckle before installing the driveshaft into the differential or intermediate shaft. Loosely install the spindle nut this time.

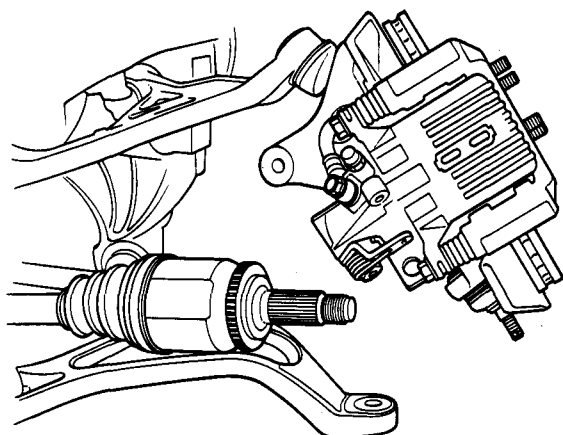

19. Install the new set rings in the driveshaft groove and intermediate shaft groove.
20. Apply a light film of grease around the set ring groove on the inboard joint, then install a new set ring and center it on the joint. The grease will keep the set ring centered, making the installation of the joint easier.
21. Install the inboard end of the driveshaft into differential or intermediate shaft.

CAUTION:

- Always use a new set ring whenever the driveshaft is being installed.
- Make sure the left driveshaft locks in the differential side gear groove, and the CV joint subaxle bottoms in the differential.
- Insert the right driveshaft CV joint subaxle into the intermediate shaft until the intermediate shaft set ring locks in the groove in the right driveshaft.

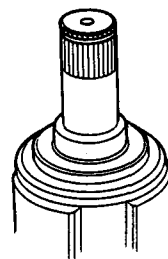
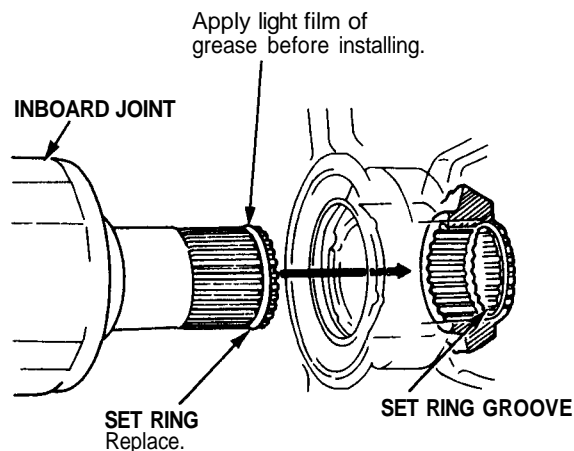

Left Driveshaft
inboard end

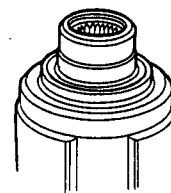

Right Driveshaft
inboard end
(Intermediate shaft side)