

Driveshafts

Disassembly

1. To remove the boot band, pry up the locking tabs with screwdriver, and raise the end of the band.

NOTE: Carefully clamp the driveshaft in a vise with soft jaws.

CAUTION: Take care not to damage the boots.

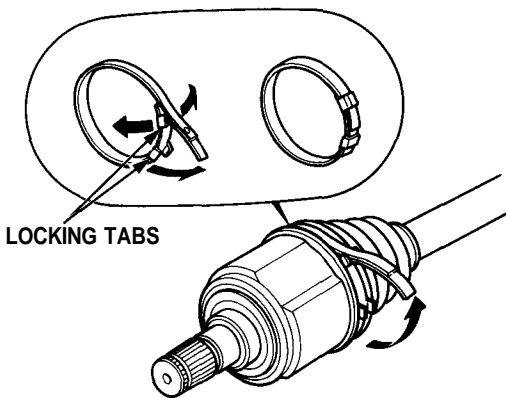

2. Remove both joints.

- Outboard joint side only:
 - Remove the circlip from the outboard joint groove.
 - Remove the outboard joint and spring.

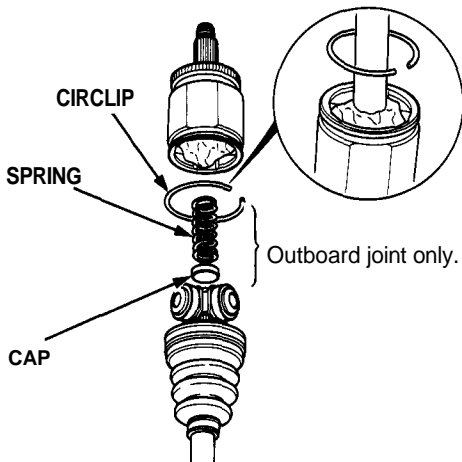

3. Remove the rollers from the spider.

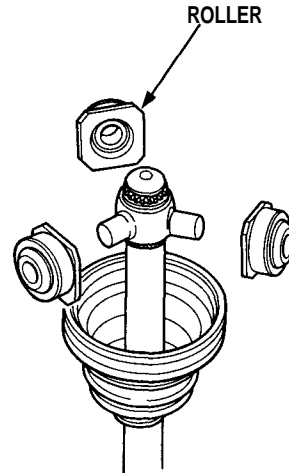

4. Remove the set ring; then remove the spider with a bearing remover.

NOTE: Before disassembly, mark the spider and driveshaft so they can be reinstalled in their original positions.

