

Preset Torque

Inspection

On-Car:

1. Block the front wheels.
2. Shift to low gear.
3. Lift up rear wheels, and place the safety stand (Lift and Support Points, see [section 1](#)).
4. Measure preset torque clockwise using a torque wrench as shown.

Standard: 120-280 N-m (12-28 kg-m,
87-203 lb-ft)

Service Limit: 60 N-m (6 kg-m, 43 lb-ft)

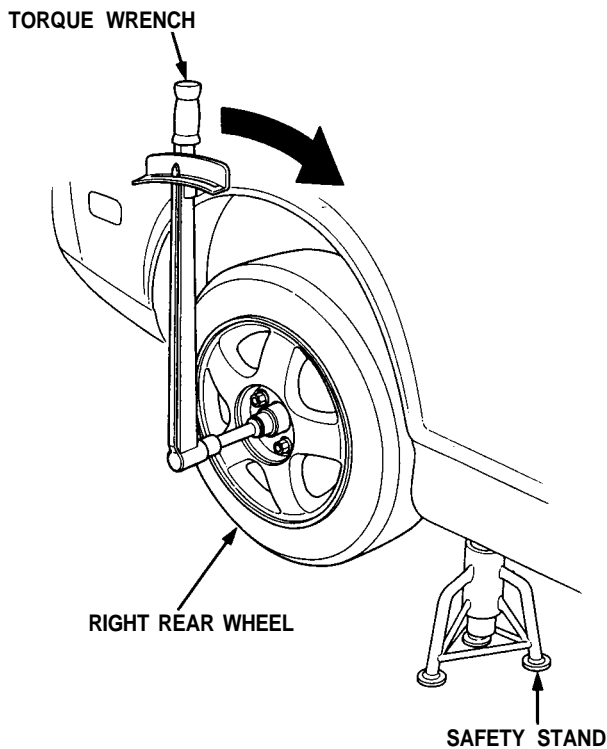

5. If preset torque is less than the service limit, replace the limited slip differential clutch set.

NOTE: Adjust the 65 mm (differential housing cover side) and 112 mm (differential housing cover side) shims whenever the clutch set is replaced.

Assembly:

1. Place one special tool in a vise. Place the left side of the differential assembly on the special tool, then preset the differential with 3-5 rotations, counterclockwise.

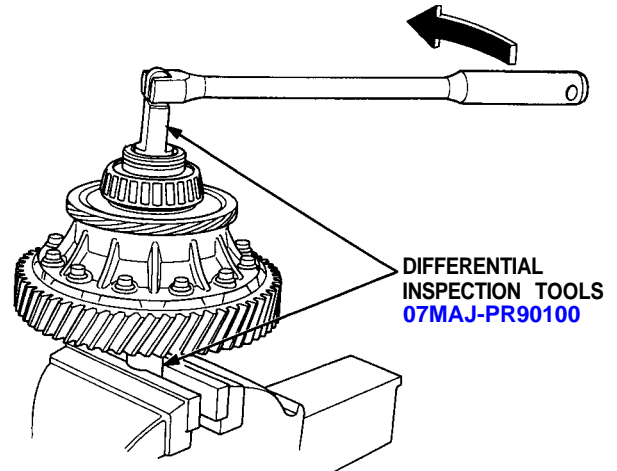

2. Measure preset torque counterclockwise using a torque wrench as shown.

Standard: 60-140 N-m (6-14 kg-m,
43-101 lb-ft)

Service Limit: 30 N-m (3 kg-m, 22 lb-ft)

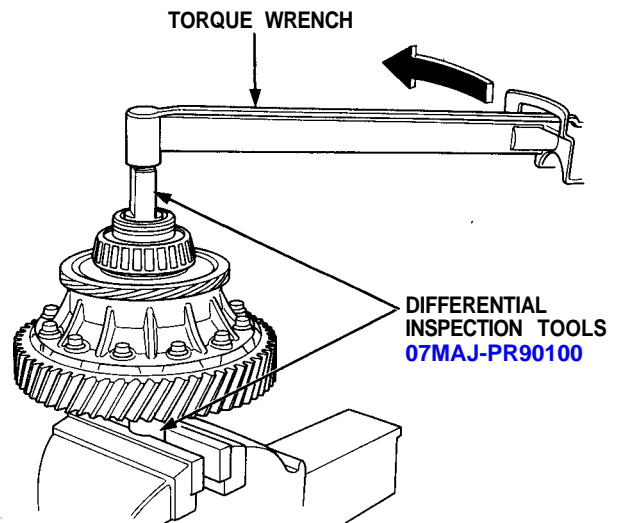

3. If preset torque is less than the service limit, replace the limited slip differential clutch set.

NOTE: Adjust the 65 mm and 112 mm shims whenever the clutch set is replaced.