

# Pressure Plate, Clutch Disc, Mid Plate

## Installation

### NOTE:

- Install the pressure plate, clutch discs, and mid plate as a set.
- Do not mix-up the 1st and 2nd clutch discs. The 2nd clutch disc has a flat plate between the two friction surfaces. The 1st clutch disc has a spring plate between the two friction surfaces.
- Use only Super High Temp Urea Grease (P/N 08798-9002).

1. Install the damper washer and spring collar.

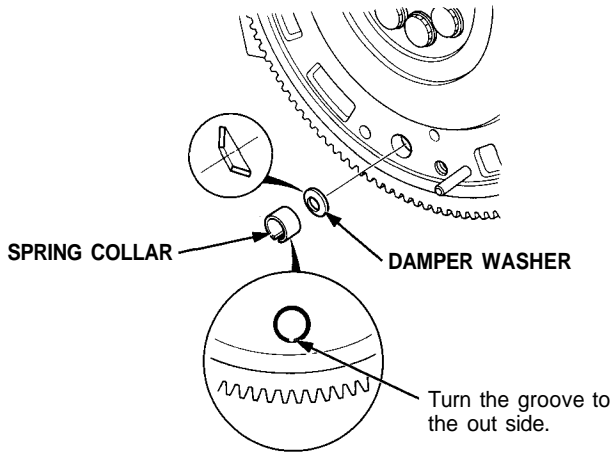

2. Install the special tool.
3. Install the 2nd clutch disc using the special tools.

NOTE: The index mark on the 2nd clutch disc should face away from the flywheel.

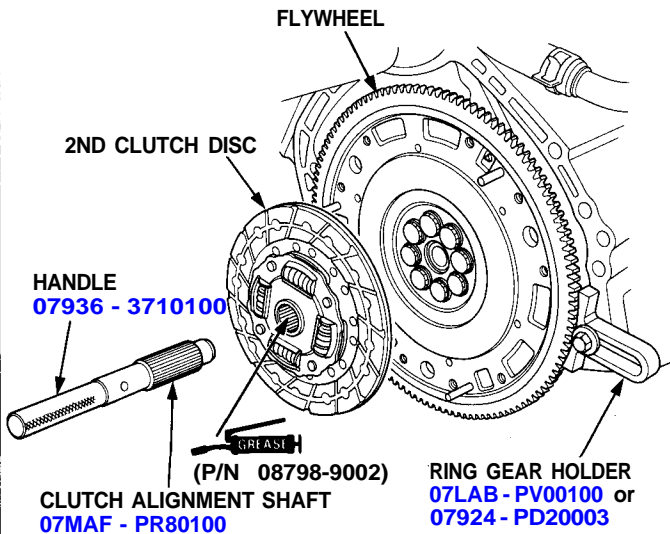

4. Install the mid plate.

NOTE: Align the mark on the flywheel with the mark on the mid plate.

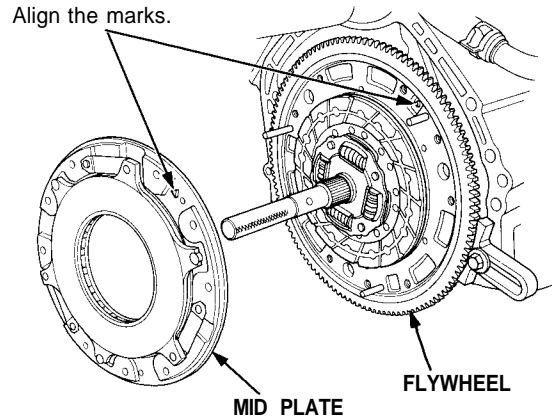

5. Install the 1st clutch disc.

### NOTE:

- The marks on the 1st and 2nd clutch discs should be 180° apart.
- The index mark on the 1st clutch disc should face away from the flywheel.

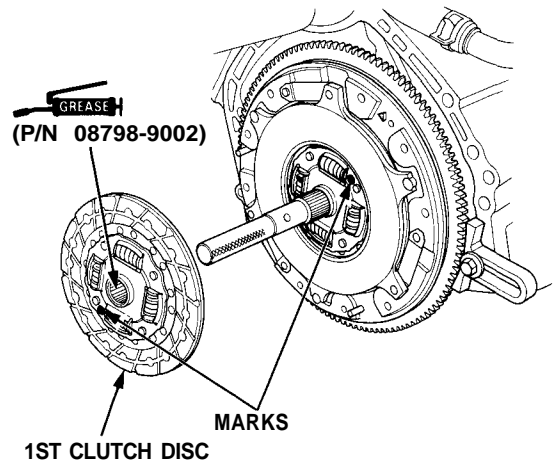



6. Install the release bearing on the pressure plate.
7. Install the pressure plate.

**NOTE:**

- Align the mark on the mid plate with the mark on the pressure plate.
- After installing, make sure the release bearing is secure.

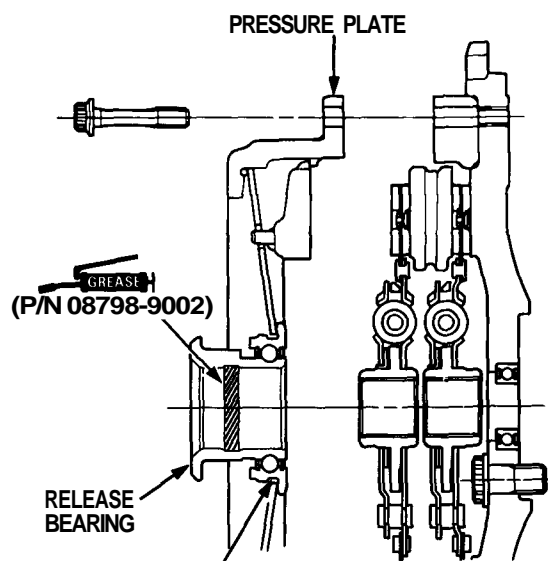
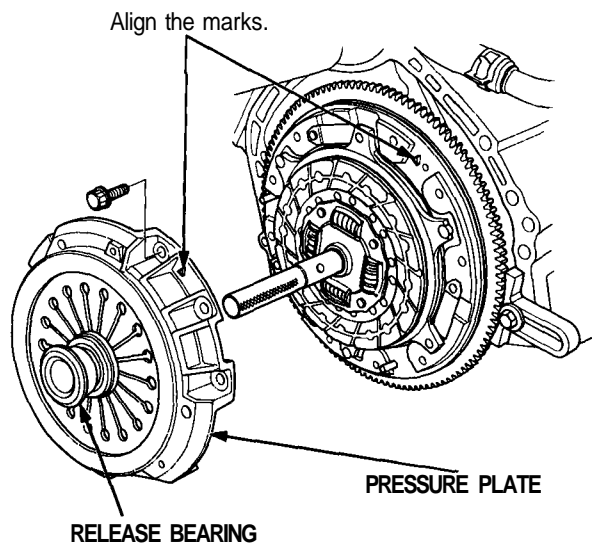

Place the diaphragm spring fingers in the groove of the release bearing.

8. Torque the mounting bolts in a crisscross pattern as shown. Tighten them several steps to prevent warping the diaphragm spring.

**NOTE:** Place the diaphragm spring fingers in the groove of the release bearing.

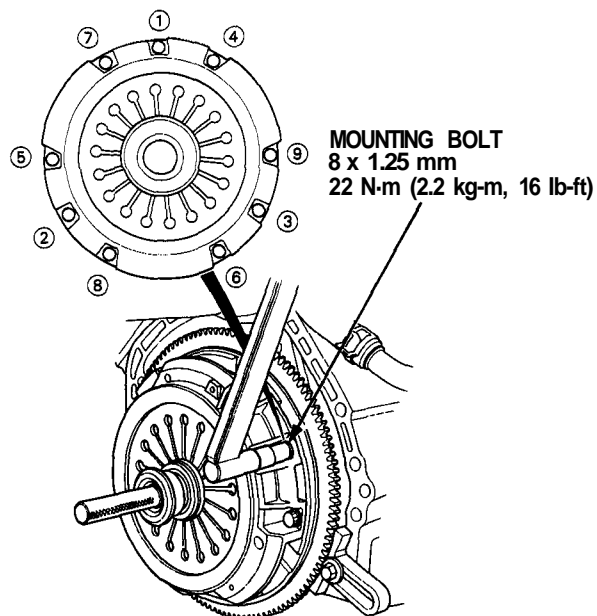

9. Remove the special tools.
10. Initialize the mid plate guides (see page [12-14](#) ('93-'96), [12-16](#) ('91-'92 Models)).