

Mid Plate Guide

Replacement (cont'd)

5. Install the new mid plate guide with the screw installed.

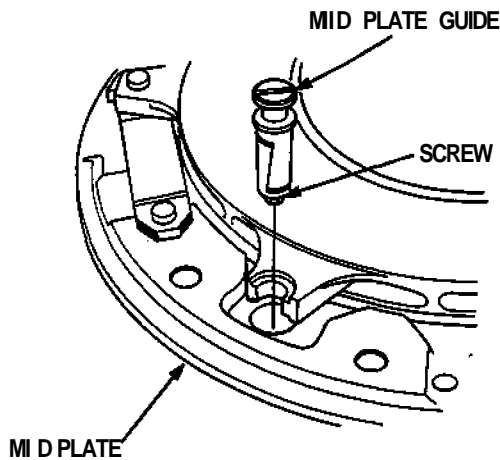

6. Install the washer, spring and guide collar, then remove the screw.

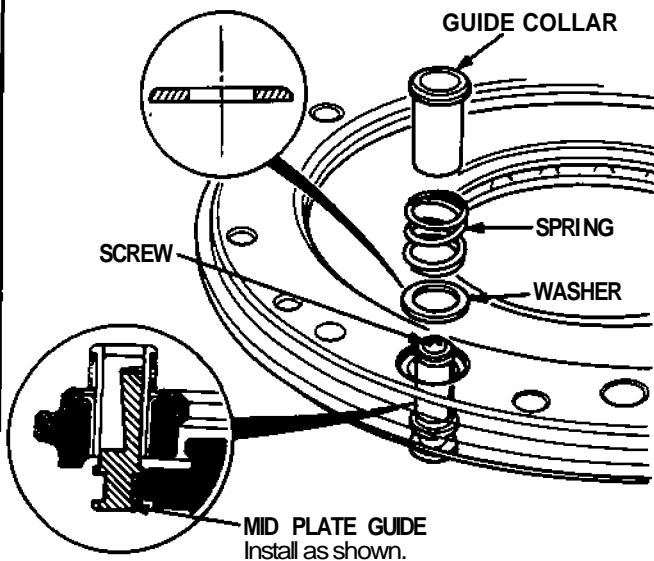

7. Initialize the mid plate guides after installing the clutch assembly (see page 12-14) assembly

Flywheel, Flywheel Bearing

Inspection

NOTE: If replacement is required, always replace the pressure plate, mid plate, and flywheel as a set.

1. Inspect the ring gear teeth for wear and damage.
2. Inspect the clutch disc mating surface on the flywheel for wear, cracks, and burning.
3. Measure the flywheel runout using a dial indicator through at least two full turns. Push against the flywheel each time you turn it to take up the crankshaft thrust washer clearance.

NOTE: The runout can be measured with engine installed.

Standard (New): 0.05 mm (0.002 in) max.
Service Limit: 0.15 mm (0.006 in)

If the runout exceeds the service limit, replace the flywheel.

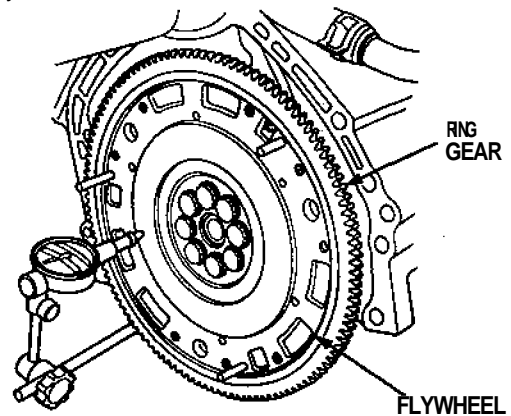

4. Turn the inner race of the ball bearing with your finger. The bearing should turn smoothly and quietly. Check that the bearing outer race fits tightly in the flywheel. Replace the bearing if the race does not turn smoothly, quietly, or fit tightly in the flywheel.

