

# Slave Cylinder

## Removal

1. Disconnect the clutch hose from the slave cylinder.

**CAUTION:**

- Avoid spilling brake fluid on the painted surfaces, as it may damage the finish.
- Plug the end of the clutch hose with a shop towel to prevent brake fluid from coming out.

2. Remove the slave cylinder from the clutch housing.

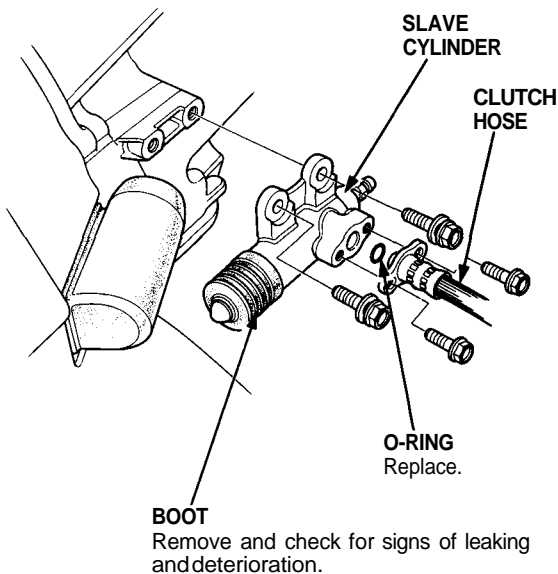

## Installation

- GREASE: Super High Temp Urea Grease (P/N 08798-9002).
- GREASE: Brake Assembly Lube or equivalent rubber grease.

1. Install the slave cylinder on the clutch housing.

**SLAVE CYLINDER**

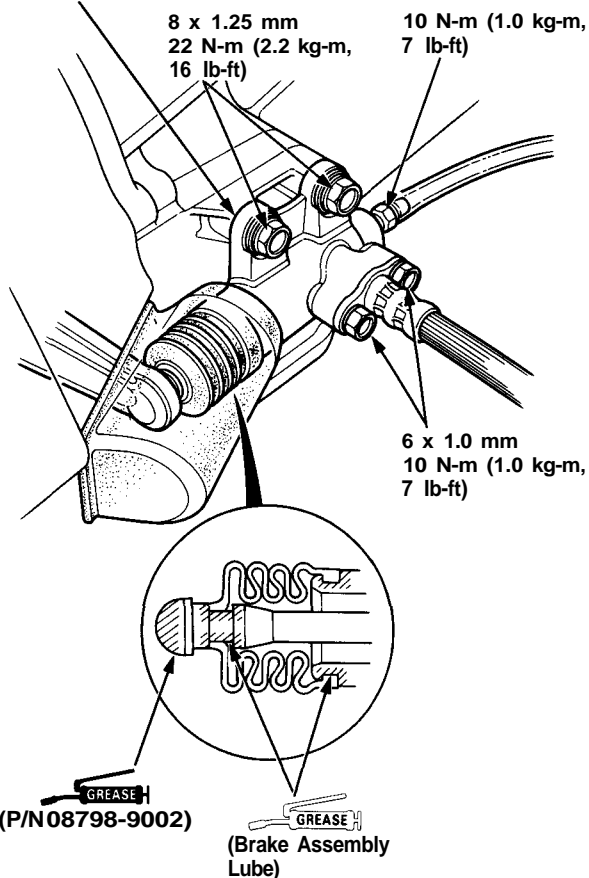

2. Bleed the clutch hydraulic system:

- Attach a hose to the bleeder screw, then suspend the hose in a container of brake fluid.
- Make sure there is an adequate supply of fluid at the master cylinder, then slowly pump the clutch pedal until no more bubbles appear at the bleeder hose.
- Refill the master cylinder fluid when done.
- Use only DOT 3 or 4 brake fluid.