

# Oil Pump

## Removal/Inspection/Installation

1. Drain the engine oil.
2. Remove the timing belt (see page 6-15('91-'93)or('94-'96)).
3. Remove the dipstick and the pipe.
4. Remove the oil filter assembly.
5. Remove the oil pan.
6. Remove the oil screen.
7. Remove the baffle plate,
8. Remove the oil pass pipe and the joint.
9. Remove the mounting bolts and the oil pump assembly.

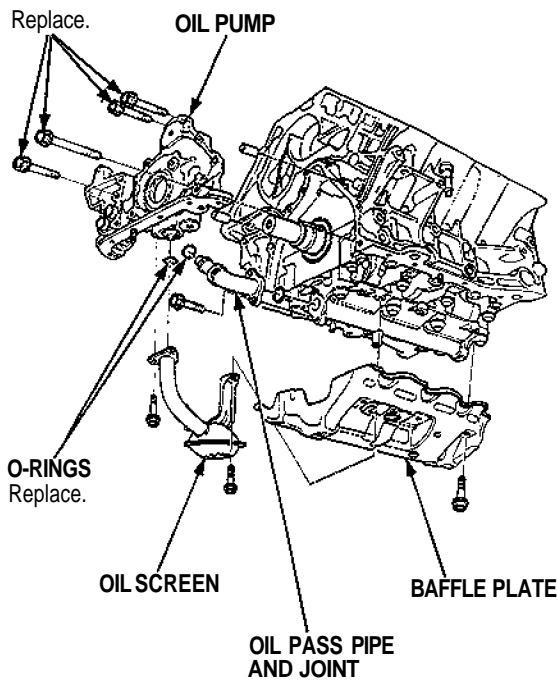

10. Remove the nine screws from the pump housing, then separate the housing and cover.
11. Check the inner-to-outer rotor radial clearance.

**Inner-to-Outer Rotor Radial Clearance**  
**Standard (New):** 0.05 – 0.21 mm  
(0.002 – 0.008 in)  
**Service Limit:** 0.23 mm (0.009 in)

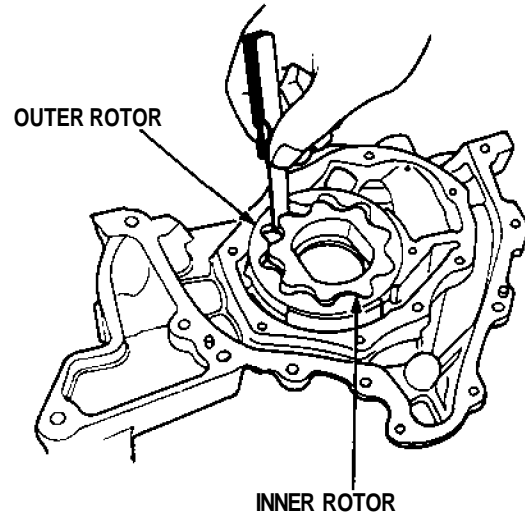

12. Check the housing-to-rotor axial clearance.

**Housing-to-Rotor Axial Clearance**  
**Standard (New):** 0.02 – 0.07 mm  
(0.001 – 0.003 in)  
**Service Limit:** 0.12 mm (0.005 in)

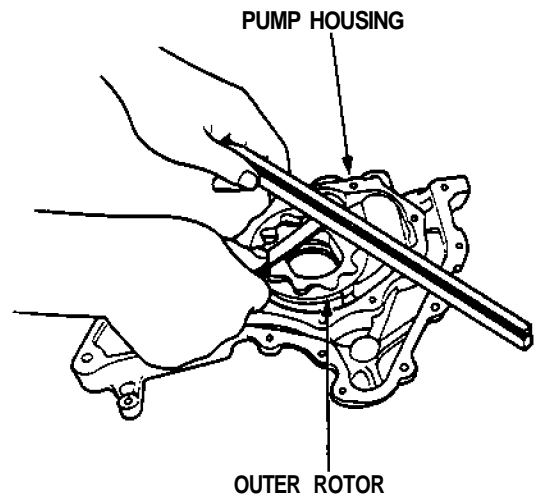



13. Check the housing-to-outer rotor radial clearance.

**Housing-to-Rotor Radial Clearance**

**Standard (New): 0.11 - 0.20 mm**

**(0.004 - 0.008 in)**

**Service Limit: 0.21 mm (0.008 in)**

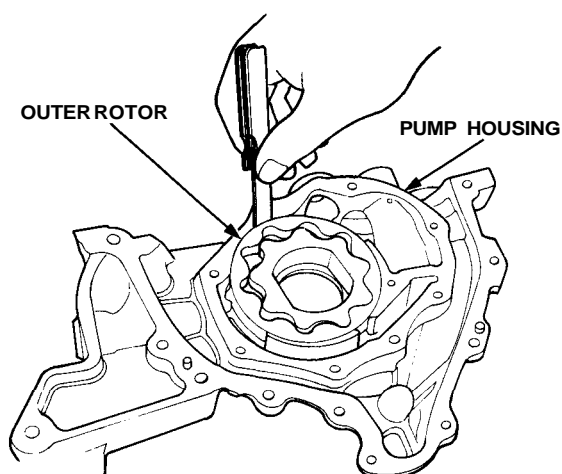

14. Inspect both rotors and the pump housing for scoring or other damage. Replace the oil pump assembly if necessary.

15. Remove the old oil seal from the oil pump.

16. Gently tap in the new oil seal until the special tool bottoms on the pump.

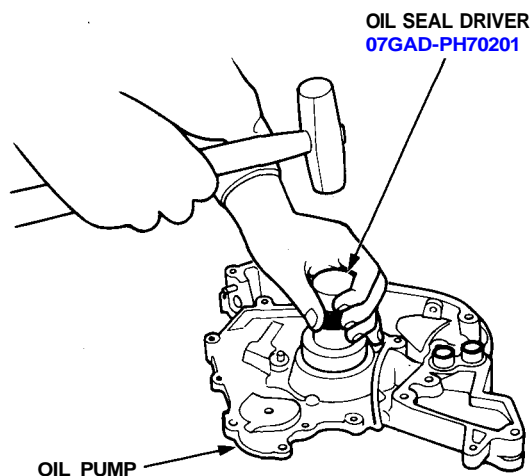

17. Reassemble the oil pump. Apply liquid thread-lock to the pump housing screws.

18. Check that the oil pump turns freely.

19. Apply a light coat of oil to the seal lip.

20. Install the two dowel pins and new O-ring on the cylinder block.

21. Apply liquid gasket to the cylinder block mating surface of the oil pump.

**NOTE:**

- Use liquid gasket, Part No. 08718-0001.
- Check that the mating surfaces are clean and dry before applying liquid gasket.
- Apply liquid gasket evenly, in a narrow bead centered on the mating surface.
- To prevent leakage of oil, apply liquid gasket to the inner threads of the bolt holes.

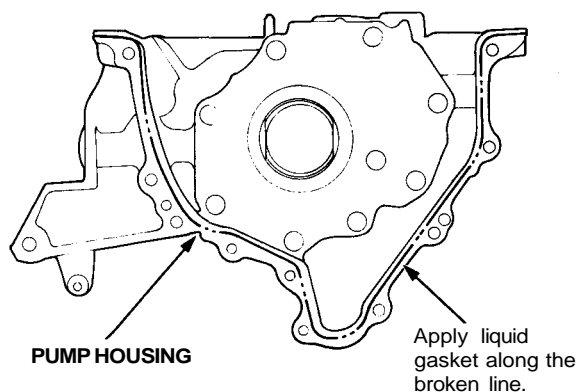

- Do not install the parts if five minutes or more have elapsed since applying liquid gasket. Instead reapply liquid gasket after removing old residue.
- After assembly, wait at least 20 minutes before filling the engine with oil.

(cont'd)

# Oil Pump

## Removal/Inspection/Installation (cont'd)

22. Install the oil pump on the cylinder block.
23. Install the oil pass pipe and joint.
24. Install the baffle plate.
25. Install the oil screen.

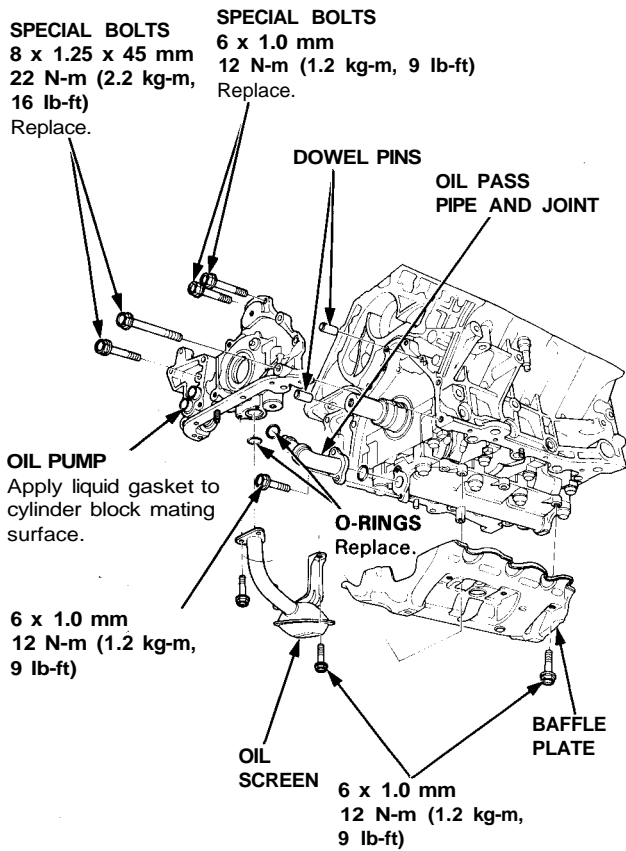

26. Apply liquid gasket to the oil pump and left side cover mating areas as shown below.

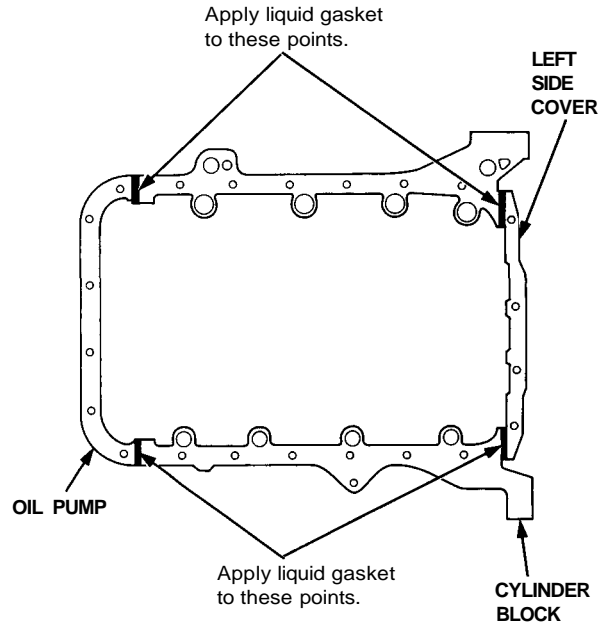

27. Install the oil pan gasket and oil pan.

NOTE: Use a new oil pan gasket.

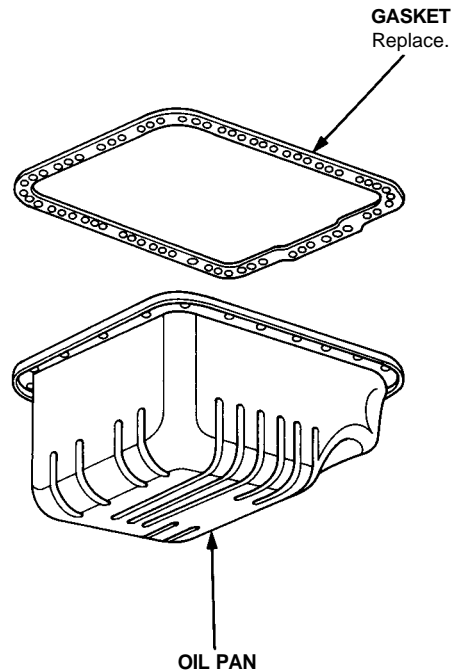



28. Tighten bolts and nuts finger tight at six points as shown below.

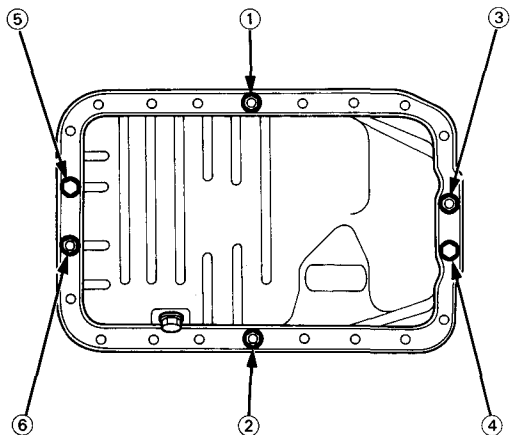

29. Starting with nut ① torque all bolts and nuts, in a clockwise pattern in three steps.

NOTE: Excessive tightening can cause distortion of oil pan gasket and oil leakage.

**Torque: 14 N-m (1.4 kg-m, 10 lb-ft)**