

Crankshaft

Installation

 Before installing the crankshaft, apply a coat of engine oil to the main bearings and rod bearings.

1. Insert bearing halves in the engine block and connecting rods.
2. Lower the crankshaft into the block.

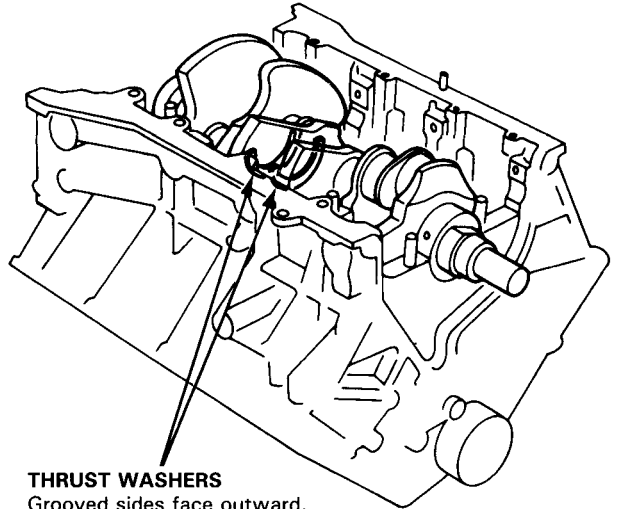

THRUST WASHERS

Grooved sides face outward.

3. Install the thrust washers on the No. 3 journal. Oil thrust washer surfaces.
4. Install the bearings and caps. Tighten 9 x 1.25 mm cap bolts to the specified torque.

Torque: 40 N·m (4.0 kg·m, 29 lb·ft)

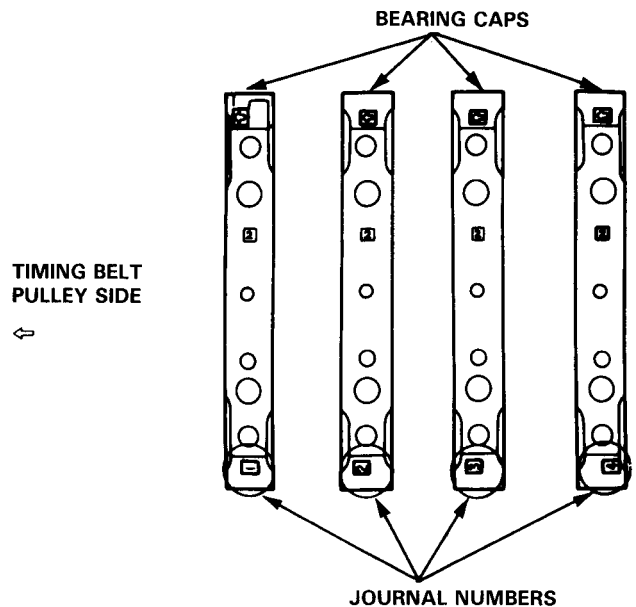



NOTE:

- Guide the piston carefully to prevent damage.
- Fit long rubber hoses (about 30 cm long) to connecting rod bolts to protect the crankshaft.
- Install the pistons after setting the crankshaft to BDC for each cylinder.

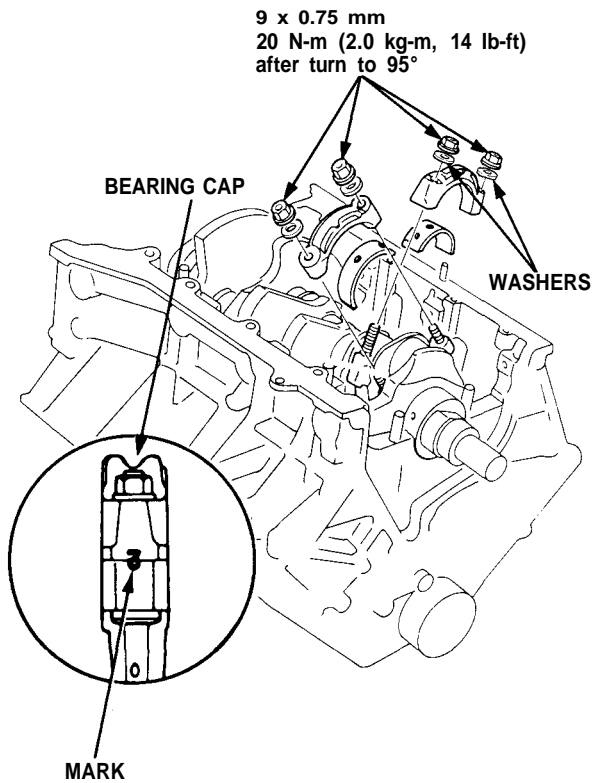
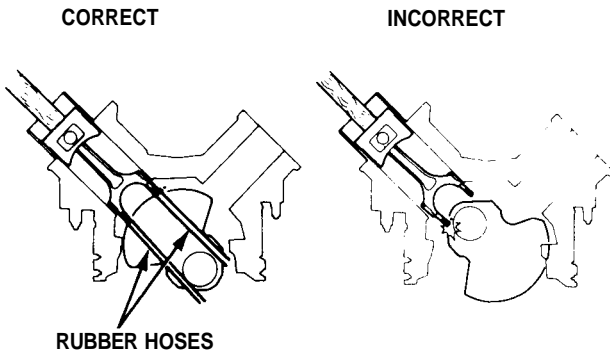

- Line up the marks when installing connecting rod cap.

5. Check the rod bearing clearance with plastigage (see page 7-7), then torque the connecting rod cap nuts.

NOTE: Reference numbers on connecting rods are for big-end bore tolerance and do NOT indicate the position of piston in engine.

CONNECTING ROD CAP NUT TORQUING METHOD

- 1) Torque the connecting rod cap nut to 20 N-m (2.0 kg-m, 14 lb-ft) with a beam-type torque wrench.
- 2) Install a torque angle gauge to the cap nut, then turn the cap nut 95 degrees.

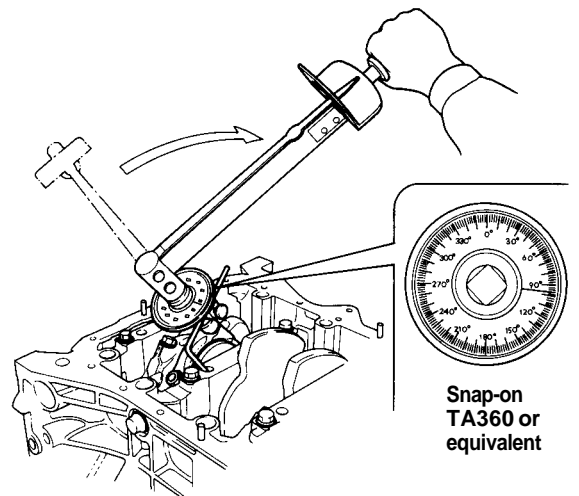

(cont'd)

Crankshaft

Installation (cont'd)

BEARING CAP BOLTS TORQUE SEQUENCE

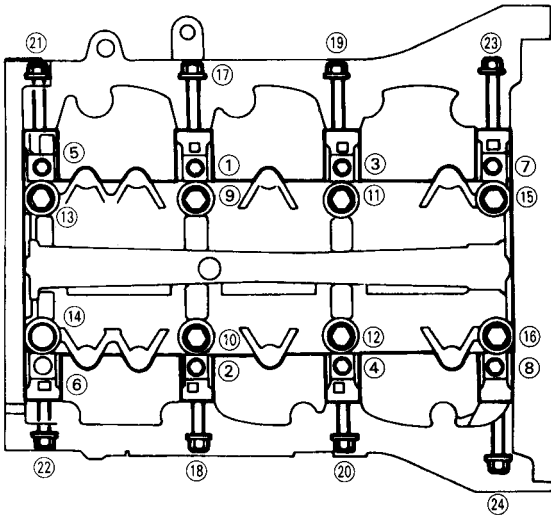

6. Install the bearing cap bridge, and tighten 11 x 1.5 mm bolts to the specified torque diagonally outward from the center.

Torque 66 N-m (6.6 kg-m, 48 lb-ft)

7. Tighten cap side bolts (10 x 1.25 mm) to the specified torque.

Torque: 50 N-m (5.0 kg-m, 36 lb-ft)

- Coat the bolt thread and seat surface with engine oil.

NOTE: The shorter side bolts are for the front side.

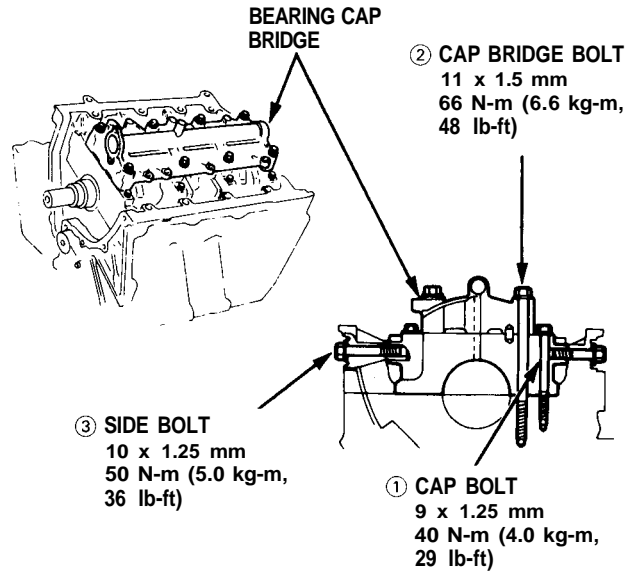

8. Apply liquid gasket to the block mating surface of the left side cover and oil pump case, and install them on the engine block.

NOTE: The seal surface on the block should be dry. Apply a light coat of oil to the crankshaft and to the lip of seal.

LEFT SIDE:

Apply liquid gasket to block mating surface.

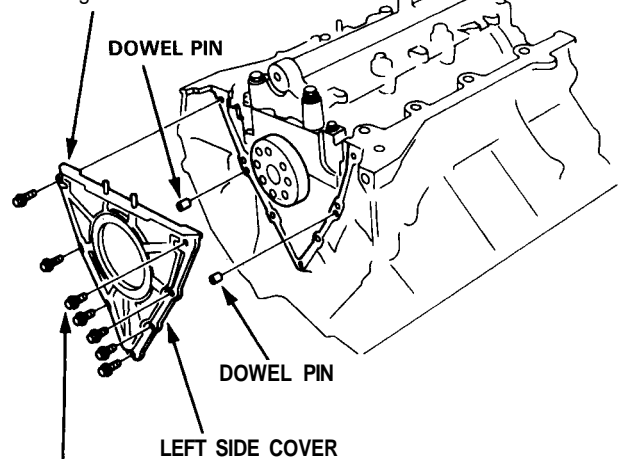

SPECIAL BOLTS
6 x 1.0 mm
12 N-m (1.2 kg-m,
9 lb-ft)
Replace.



OIL PUMP SIDE:

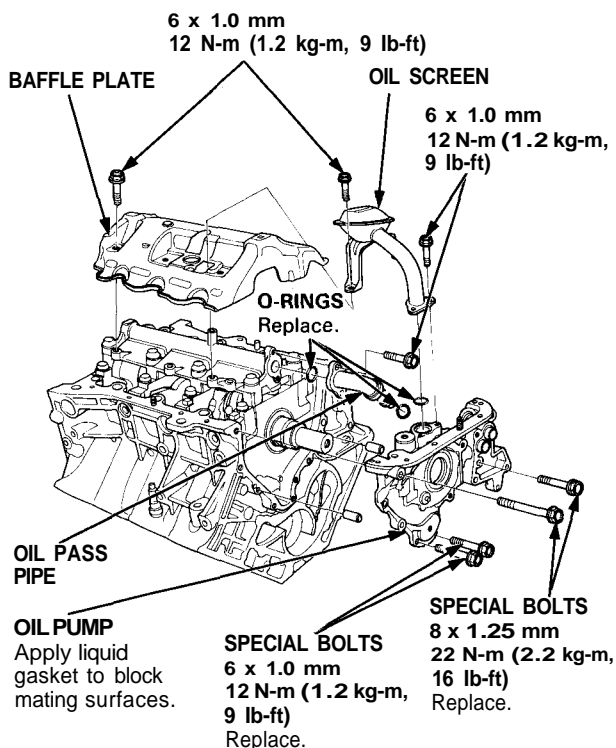

NOTE:

- Use liquid gasket, Part No. 08718-0001.
- Check that the mating surfaces are clean and dry before applying liquid gasket.
- Apply liquid gasket evenly, being careful to cover all of the mating surface.
- To prevent leakage of oil, apply liquid gasket to the inner threads of the bolt holes.

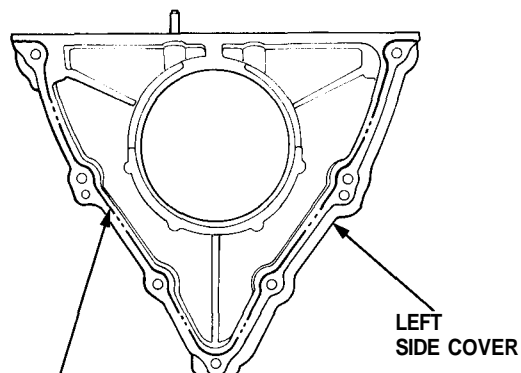

Apply liquid gasket along the broken line.

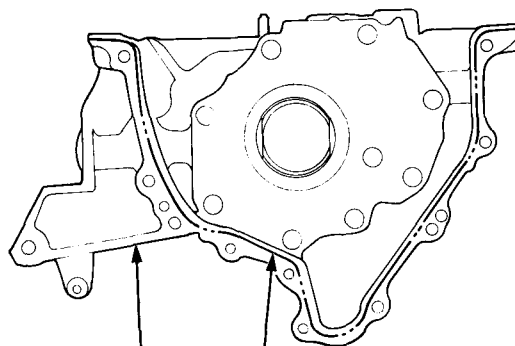

Apply liquid gasket along the broken line.

- Do not install the parts if five minutes or more have elapsed since applying liquid gasket. Instead reapply liquid gasket after removing old residue.
- After assembly, wait at least 20 minutes before filling the engine with oil.

9. Install the oil pass pipe and joint.
10. Install the baffle plate.
11. Install the oil screen.
12. Install the oil pan (see page 8-10).

CAUTION: Whenever any crankshaft or connecting rod bearing is replaced, after reassembly, run the engine at idling speed until it reaches normal operating temperature, then continue to run for approximately 15 minutes.