

# Piston Rings

## Ring-to-Groove Clearances

After installing a new set of rings, measure ring-to-groove clearances:

**Top and Second Ring Clearance**  
**Standard (New): 0.030-0.055 mm**  
**(0.001 - 0.002 in)**  
**Service Limit: 0.13 mm (0.005 in)**

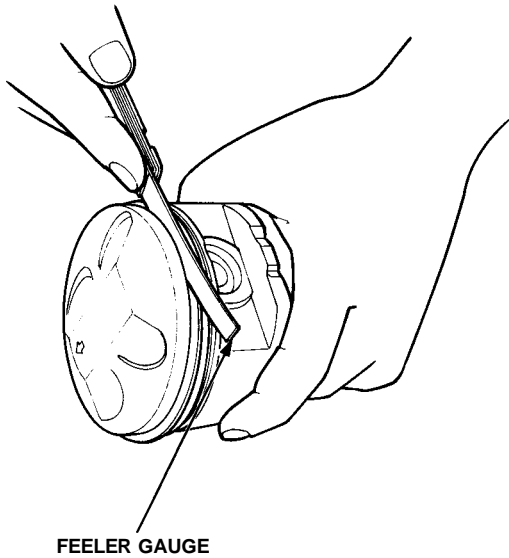

## Alignment

1. Install the rings as shown on page 7-15.

Identify top and second rings by the chamfer on the edge, and make sure they are in the proper grooves in the piston.

NOTE: The manufacturing marks must be facing upward.

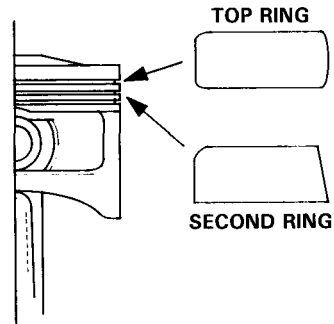

2. Rotate the rings in their grooves to make sure they do not bind.

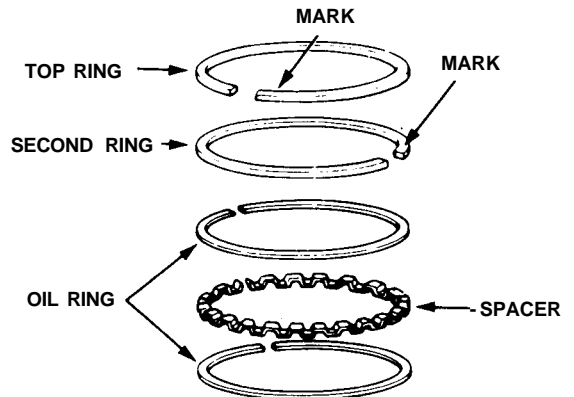

3. Position the ring end gaps as shown:

