

VTEC

VTEC Solenoid Valve Inspection

1. Disconnect the 2P connector from the VTEC solenoid valve.
2. Measure resistance between the BLU/YEL (front/rear) terminals and body ground.

Resistance: approx 14 - 30 ohms

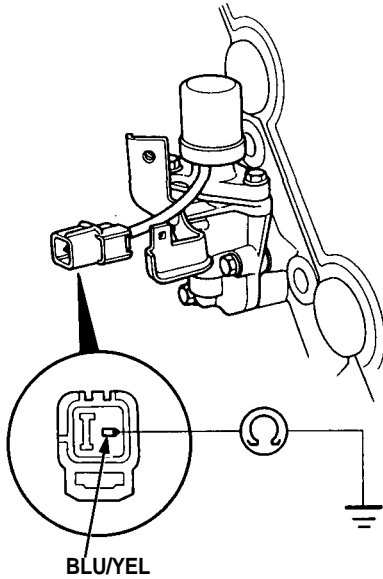

3. If the resistance is within specifications, remove the VTEC solenoid valve from the cylinder head, and check the VTEC solenoid valve filter for clogging.
 - If there is clogging, replace the engine oil filter and engine oil.

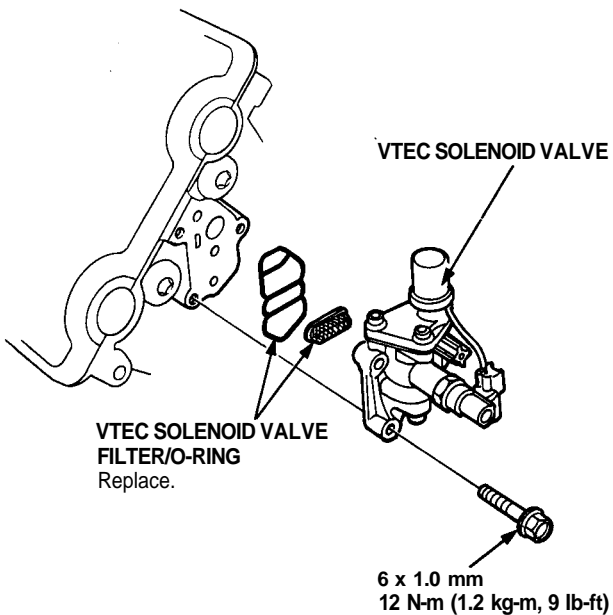

4. If the filter is not clogged, push the VTEC solenoid valve with your finger and check its movement.
 - If VTEC solenoid valve is normal, check the engine oil pressure.

