

Engine Removal/Installation



Installation

Additional Torque Value Specifications:

NOTE: For manifold replacement, refer to [section 9](#).

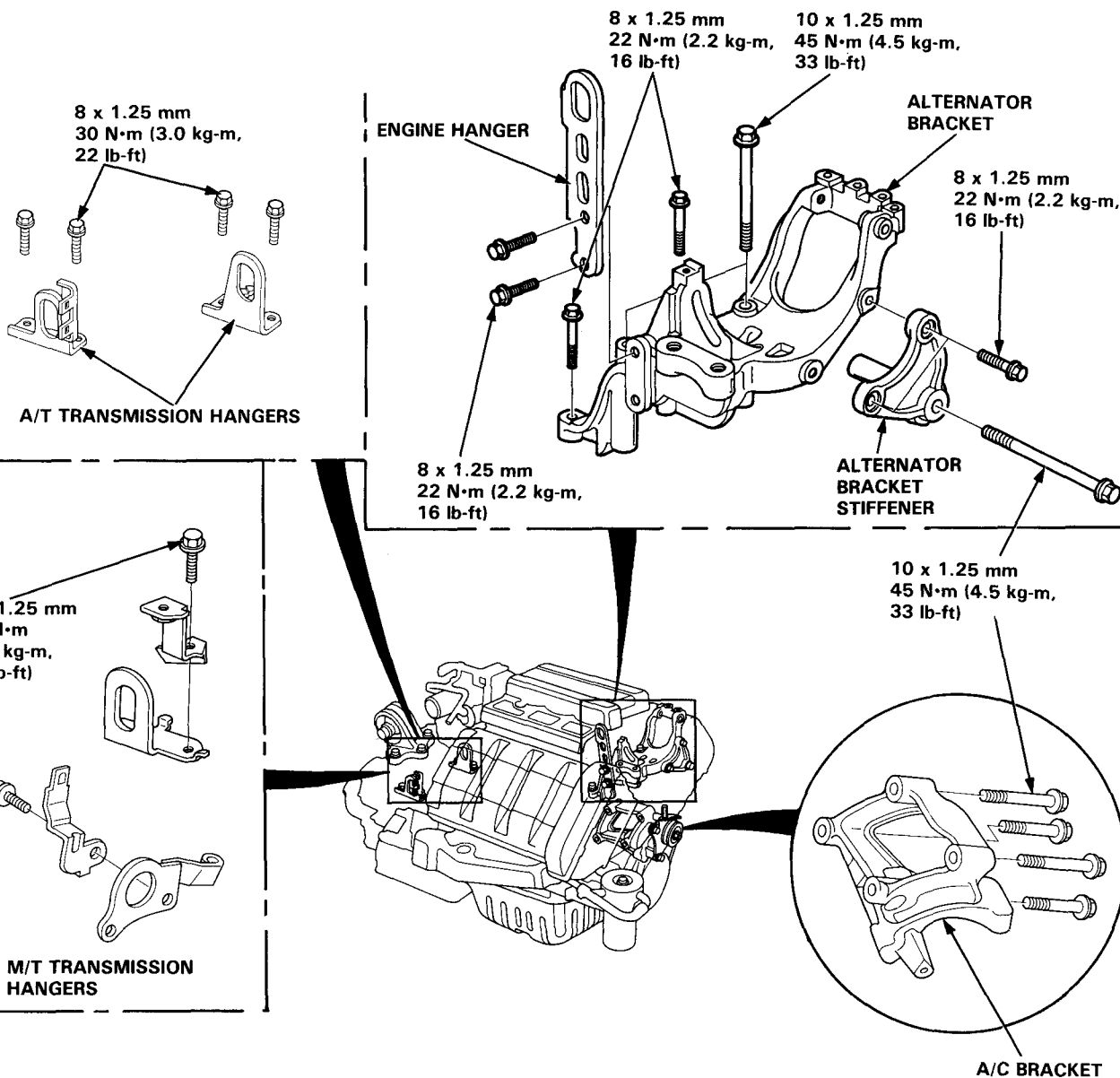

(cont'd)

Engine Removal/Installation

Installation (cont'd)

Engine Installation:

Install the engine in the reverse order of removal. Reinstall the mount bolts/nuts in the following sequence, failure to follow these procedures may cause excessive noise and vibration, and reduce bushing life.

1. Install the rear mount, then tighten the bolts on the transmission side.

NOTE: Do not tighten the mounting bolt.

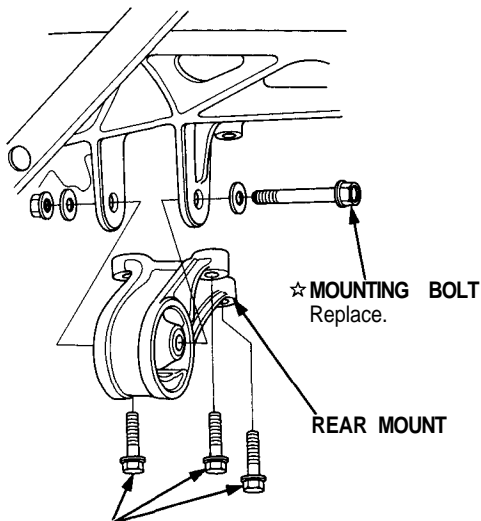

M/T: ☆12 x 1.25 mm
105 N-m (10.5 kg-m, 76 lb-ft)
A/T: ☆10 x 1.25 mm
60 N-m (6.0 kg-m, 43 lb-ft)

2. Install the front mount, then tighten the bolts in the numbered sequence as shown (① - ②).

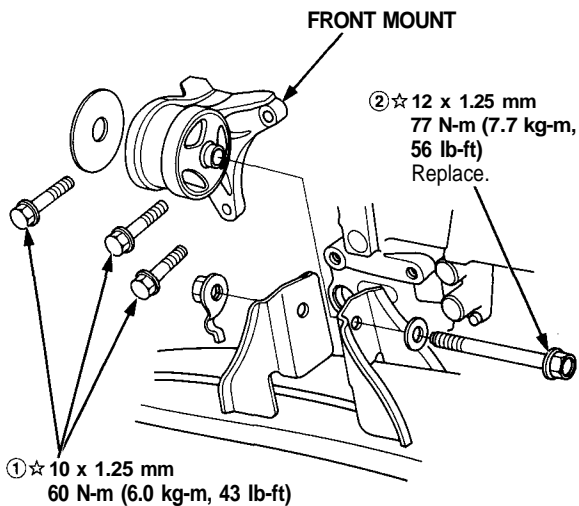

☆: CORROSION RESISTANT BOLT/NUT

3. Install the subframe, then tighten the subframe-to-body mounting bolts (see section 20).

NOTE: Align the bolt holes of the beam brackets and body with a tapered punch.

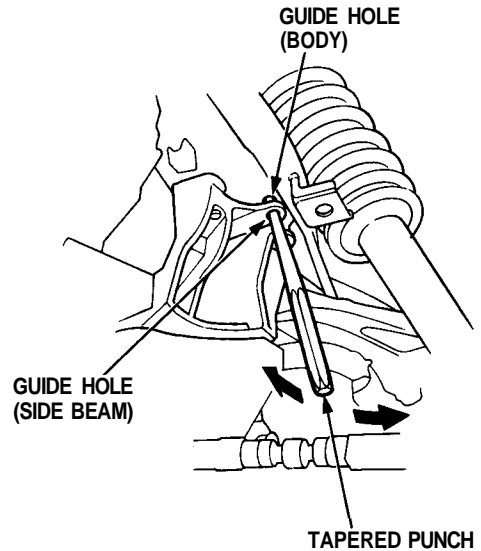

4. Install the transmission mount, then tighten the bolts on the transmission side.

NOTE: Do not tighten the mounting bolt.

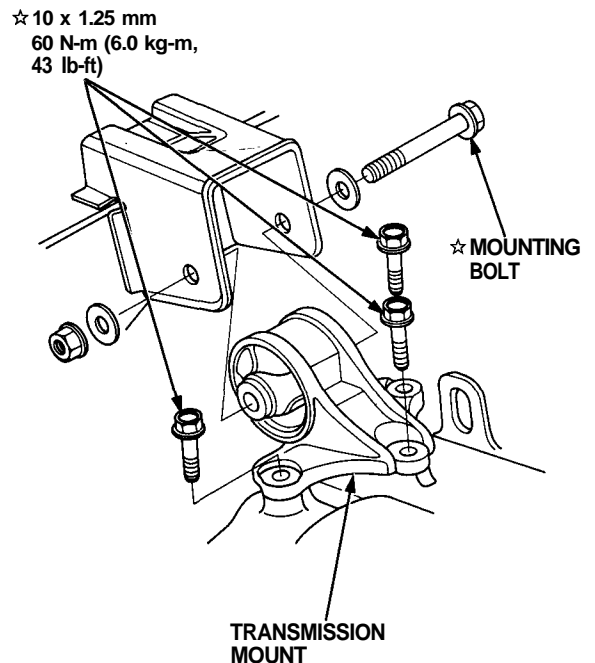

☆10 x 1.25 mm
60 N-m (6.0 kg-m,
43 lb-ft)



5. Install the side engine mount, then tighten the bolts in the numbered sequence as shown (① - ②),

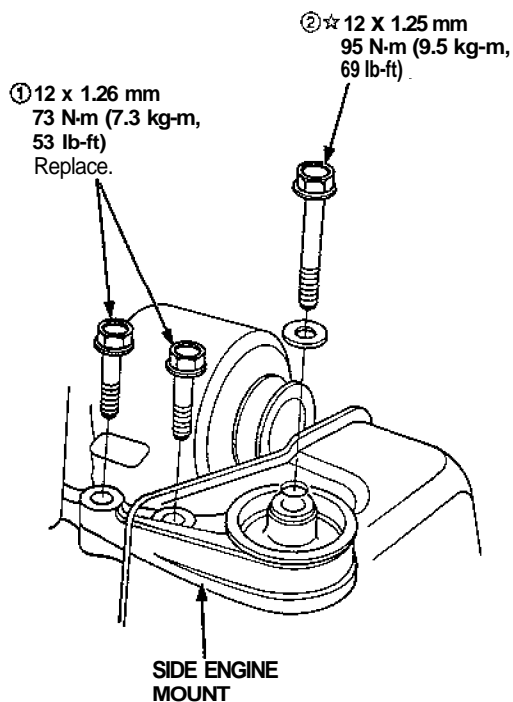

6. Tighten the transmission mount mounting bolt.

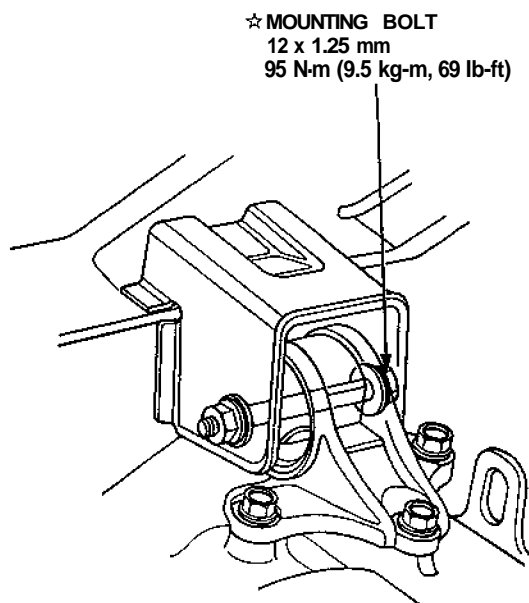

7. Tighten the rear mount mounting bolt.

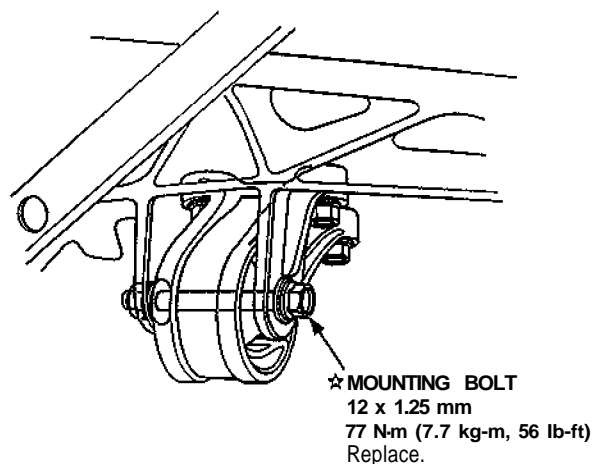

- Check that the spring clip on the end of each driveshaft clicks into place.

CAUTION: Use new spring clips.

- Bleed air from the cooling system (see page 10-5).
- Bleed air from the brake lines (see section 19).
- Check the clutch pedal free play (see section 12).
- Adjust the clutch guide assemblies when disassembling clutch (see section 12).
- Check that the transmission shifts into gear smoothly.
- Adjust the alternator belt (see section 23).
- Adjust the A/C compressor belt (see section 22).
- Clean battery posts and cable terminals with sandpaper, assemble, then apply grease to prevent corrosion.
- Inspect for fuel leakage (see section 11).
 - After assembling the fuel line parts, turn on the ignition switch (do not operate the starter) so that the fuel pump operates for approximately two seconds and the fuel line pressurizes. Repeat this operation two or three times and check for fuel leakage at any point in the fuel line.
- Check and adjust wheel alignment (see section 18).
- Refill the engine with engine oil (see page 8-4 ('91-'92 Models), ('93-Model), or ('94-'96 Models)).
- Refill the transmission with oil/fluid (see section 13 or 14).